

# YEAR 7 JUNE REVISION

## NUMBER.

- Do the following calculations, showing **ALL** your working in full.
  - $307 + 137$
    - $3472 + 169$
    - $386 - 144$
    - $225 - 176$
    - $25 \times 15$
    - $145 \times 342$
    - $8 \overline{)424}$
    - $16 \overline{)424}$ .
  - $12.6 + 3.28$
    - $5.8 + 4.32$
    - $21.97 - 7.24$
    - $13.5 - 4.6$
    - $7.4 \times 1.6$
    - $5.14 \times 3.2$
    - $5.2 \div 8$
    - $9.65 \div 5$ .
- Write down the answers to the following: (**Do NOT use long multiplication/division!**)
  - $15 \times 10$
  - $15 \times 100$
  - $15 \times 1000$
  - $15 \times 10000$
  - $12.6 \times 100$
  - $0.134 \times 10$
  - $300 \div 100$
  - $30 \div 100$
  - $35.523 \div 1000$
  - $0.01 \div 10$ .
- Write down all the factors of the following numbers.
  - 12,
  - 24,
  - 50,
  - 100,
  - 40.
- Find the **highest common factors** of the following pairs of numbers.
  - 6, 18,
  - 6, 20,
  - 8, 25,
  - 16, 40,
  - 24, 60.
- Write down the first 5 multiples of the number 5.
  - Write down the first 5 multiples of the number 8.
- Express each of the following numbers as a product of primes.
  - 60,
  - 50,
  - 40,
  - 120,
  - 400.
- Arrange in order of size, putting the smallest first:
  - 8.91, 8.901, 8.019, 8.109.
  - 0.16, 0.016, 0.106, 0.61.
  - 5.061, 56.1, 5.601, 0.561, 5.61.
  - 7, 5, -3, -9, 2.
  - 5, -8, -4, 1, 3, 0.
- Do the following calculations without the aid of a calculator.
  - $15 - 24$ ,
  - $-7 + 16$ ,
  - $14 + (-11)$ ,
  - $-4 \times (-7)$ ,
  - $-11 \times (6)$ ,
  - $12 + 5 \times 4$ ,
  - $10 + 4 \times 5 - 2 \times 6$ ,
  - $15 + 3 \times (16 - 14)^2$ ,
  - $5^2 - 10$ ,
  - $-3 \times (-2) + 12$ ,
  - $4 + (-3)^2$ ,
  - $4 - (-3)^2$ ,
  - $-3 \times (-7)$ ,
  - $-2 \times (4) + 2 \times 4$ ,
  - $(3 \times -2)^2$ ,
  - $2^3 + 2 \times (3 + 6)$ .

9. Cancel the following fractions down to their simplest form.  
 a)  $\frac{2}{4}$ , b)  $\frac{2}{6}$ , c)  $\frac{2}{8}$ , d)  $\frac{20}{30}$ , e)  $\frac{15}{20}$ , f)  $\frac{24}{40}$ , g)  $\frac{12}{80}$ , h)  $\frac{22}{55}$ , i)  $\frac{45}{54}$ , j)  $\frac{26}{39}$ .
10. Write the following fractions in top heavy form.  
 a)  $1\frac{1}{2}$ , b)  $2\frac{1}{3}$ , c)  $3\frac{2}{5}$ , d)  $4\frac{1}{9}$ , e)  $10\frac{3}{4}$ , f)  $7\frac{2}{7}$ .
11. Work out:  
 a)  $\frac{1}{4} + \frac{2}{5}$ , b)  $\frac{5}{8} - \frac{1}{4}$ , c)  $1\frac{2}{3} + \frac{2}{5}$ , d)  $\frac{2}{3} \times \frac{3}{5}$ , e)  $\frac{4}{9} \times \frac{6}{11}$ , f)  $1\frac{3}{5} \times 2\frac{1}{2}$ .
12. Work out the following:  
 a) 10% of £200, b) 20% of £60, c) 15% of £80, d) 15% of £300,  
 e) 5% of £40, f) 25% of £40, g) 12% of £200, h) 24% of £400,  
 i) 16% of £150, j) 16% of £175, k) 22% of £50, l) 11% of £60.
13. a) Mark scores 6 out of 10 in a test. What percentage is this ?  
 b) Jane scores 20 out of 25 in a test. What percentage is this ?  
 c) Sammy scores 24 out of 40 in a test. What percentage is this ?  
 d) Express 18 as a percentage of 60.  
 e) Express 80 as a percentage of 200.  
 f) Express 120 as a percentage of 400.
14. a) Write correct to 3 **decimal places**. i) 6.5889, ii) 22.9485, iii) 0.00566,  
 iv) 1.1596.  
 b) Write correct to 3 **significant figures**: i) 8506, ii) 0.005275, iii) 599,  
 iv) 91960.

### ALGEBRA.

1. Write the following numbers as powers of 2.  
 a) 16, b) 4, c) 64, d) 2, e) 256.
2. Write the number 81 as a power of 3.
3. Given that  $a = 3$ ,  $b = 4$ , and  $c = -3$ , work out the values of the following.  
 a)  $a + 2b$ , b)  $3a + b$ , c)  $3(a + 2b)$ , d)  $a^2 + b^2$ ,  
 e)  $a^2b$ , f)  $ab^2$ , g)  $ab + c$ , h)  $c^2$ ,  
 i)  $a - c$ , j)  $a + c$ , k)  $a(a + b) + bc$ , l)  $ac - ca$ ,  
 m)  $2a - c$ , n)  $a(2b - c)$ , o)  $3(a + b)^2$ , p)  $(a - b)(a + b)$ .
4. Simplify the following by collecting like terms.  
 a)  $6a + 5b + 3a + 2b$ , b)  $8a + 9b - 2a + 3b$ ,  
 c)  $12a + 2b + 3a + 5 + 3b - 3$ , d)  $8a + 3b - 3a + 10 - 5b - 2$ ,  
 e)  $4a + 9b - 9a + 5b$ , f)  $2ab + 2a + 3ab - 3a$ ,  
 g)  $5ab + 2a + 6 - 3ab - 10 + a$ , h)  $3a^2 + ab + a^2 - ab$ ,  
 i)  $3a^2 + b^2 + 6a + 3b^2 - 2a + 2a^2$ , j)  $16a + a^2 - 12a + 4 + 2a^2$ .

5. Simplify the following.

a)  $5 \times 2a$ ,

b)  $10 \times 3a$ ,

c)  $2a \times 3a$ ,

d)  $2a \times 3a^2$ ,

e)  $4a^2b \times 3ab$ ,

f)  $5(a + 2)$ ,

g)  $4(2a + 10)$ ,

h)  $2(10 + a) + 4a$ ,

i)  $2(5 - a) + 4a$ ,

j)  $3(2 + a) + 2(3 + a)$ ,

k)  $3(2a + 6) + 3a$ ,

l)  $3(6 - 4a) + 2 + 3a$ ,

m)  $50 - 5(6 + a)$ ,

n)  $10a - 2(3a + 5)$ ,

o)  $8a + 12 - 3(2a - 1)$ ,

p)  $6a + 5 - 4(2 - 3a)$ .

6. i) Solve the following equations.

a)  $4x + 3 = 23$ ,

b)  $6x - 5 = 37$ ,

c)  $5(x + 1) = 45$ ,

d)  $4(2x - 1) = 28$ ,

e)  $2x + 12 = x + 20$ ,

f)  $3x + 3 = x + 7$ ,

g)  $4x + 12 = 2x + 26$ ,

h)  $3x - 5 = x - 13$ ,

i)  $3x + 1 = 16$ ,

j)  $2x - 7 = x + 7$ ,

k)  $2x + 5 = x + 1$ ,

l)  $5(x + 1) = 40$ ,

m)  $5x + 7 = 57$ ,

n)  $11 + 2x = 26 - x$ ,

o)  $4(x + 1) = 2x + 6$ ,

p)  $2(3x - 4) = 22$ ,

q)  $3x + 1 = 13$ ,

r)  $4x + 5 = 2x - 7$ ,

s)  $5(x - 1) = 2x + 4$ ,

t)  $3x + 18 = 24$ ,

u)  $2x + 3 = 25$ ,

v)  $4x + 6 = 2x + 12$ ,

w)  $4x - 6 = x + 6$ ,

x)  $5x = 30$ ,

y)  $\frac{x}{6} + 8 = 18$ ,

z)  $10 - 2x = 2$ .

ii) Solve the following equations.

a)  $4(x - 2) = 2(x + 3)$ ,

b)  $3(2x + 4) = 4(x + 4)$ ,

c)  $3(2x - 1) = 4(x + 1)$ ,

d)  $4(2x + 1) = 6(x + 3)$ ,

e)  $7(x - 3) = 11 - x$ ,

f)  $2(x - 10) = 5 - 3x$ ,

g)  $3(x - 1) = 2(x + 7)$ ,

h)  $x + 2(x + 4) = 17$ ,

i)  $2(5 + x) = x + 20$ ,

j)  $3(2x + 4) + 2(3x + 2) = 28$ ,

k)  $100 - 2(10 + x) = 60$ ,

l)  $10 - 3(3 - x) = 4$ ,

m)  $10 - x = 12$ ,

n)  $3x + 2(x + 1) = 3x + 12$ ,

o)  $10 - 3(3 - x) = 16$ .

**Answer questions 7) – 11) on graph paper.**

7. Draw a set of axes with  $x$  from  $-4$  to  $+4$  and  $y$  from  $-8$  to  $+10$ . Draw and label the following graphs on your axes.

a)  $x = 3$ ,

b)  $y = 4$ ,

c)  $x = -2$ ,

d)  $y = x + 4$ ,

e)  $y = 2x + 1$ .

8. Draw a set of axes with  $x$  from  $-3$  to  $+3$  and  $y$  from  $-10$  to  $+10$ . Draw and label the following graphs on your axes.

a)  $y = x + 3$ ,

b)  $y = 4 - 2x$ ,

c)  $y = 3x + 1$ ,

d)  $x + y = 6$ .

9. Draw a set of axes with  $x$  from  $-5$  to  $+8$  and  $y$  from  $-8$  to  $+10$ . Draw and label the following graphs on your axes.

a)  $x = -4$ ,

b)  $y = -3$ ,

c)  $y = x + 1$ ,

d)  $y = 2x - 1$ ,

e)  $x + y = 5$ .

10. Two towns,  $A$  and  $B$ , are 80 km apart. Sally leaves town  $A$  at 12:00 p.m. and travels towards  $B$ . She travels at 20 km/h for 1 hour, and then rests for  $\frac{1}{2}$  hour. She then continues at 20 km/h for another hour before resting again for 1 hour. She then completes her journey at a constant 20 km/h.

a) On graph paper, draw the travel graph of Sally's journey.

**Use a scale of 2 cm for 1 hour on the horizontal axis and 2 cm for 10 km on the vertical axis.**

b) What time does Sally arrive at town  $B$ ?

Barry leaves town  $B$  at 2 p.m. and travels towards town  $A$  at a constant 30 km/h.

**Draw Barry's journey on the above graph.**

c) At what time did Barry arrive home?

d) At what time did Sally and Barry pass each other?

11. Two towns,  $A$  and  $B$ , are 60 km apart. Susan leaves town  $A$  at 12:00 p.m. and travels towards  $B$ . She travels at 15 km/h for 2 hours, and then rests for  $1\frac{1}{2}$  hours. She then continues at 20 km/h for another hour before resting again for 1 hour. She then takes exactly  $\frac{1}{2}$  hour to complete her journey.

a) On graph paper, draw the travel graph of Susan's journey.

**Use a scale of 2 cm for 1 hour on the horizontal axis and 2 cm for 10 km on the vertical axis.**

b) What time does Susan arrive at town  $B$ ?

c) How fast does Susan travel in the last  $\frac{1}{2}$  hour of her journey?

Ben leaves town  $B$  at 3 p.m. and travels towards town  $A$  at a constant 30 mph.

**Draw Ben's journey on the above graph.**

d) At what time did Ben arrive at town  $A$ ?

e) At what time did Susan and Ben pass each other?

**SHAPE & SPACE.**

1. Use a ruler, protractor and a compass to draw, accurately, the following shapes. Measure and write down the lengths of  $a$ , and  $b$  and the size of angles  $A$ ,  $B$ , and  $C$ .

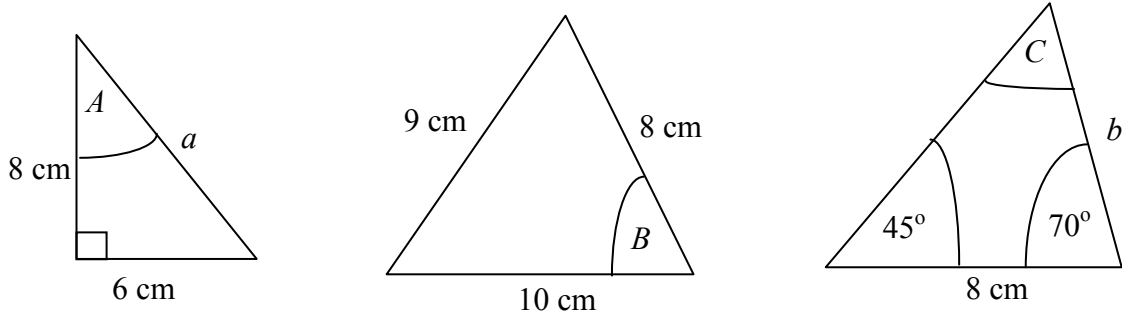

2. Find, by calculation, the angles marked with letters (DO NOT measure; **NOT to scale!**)

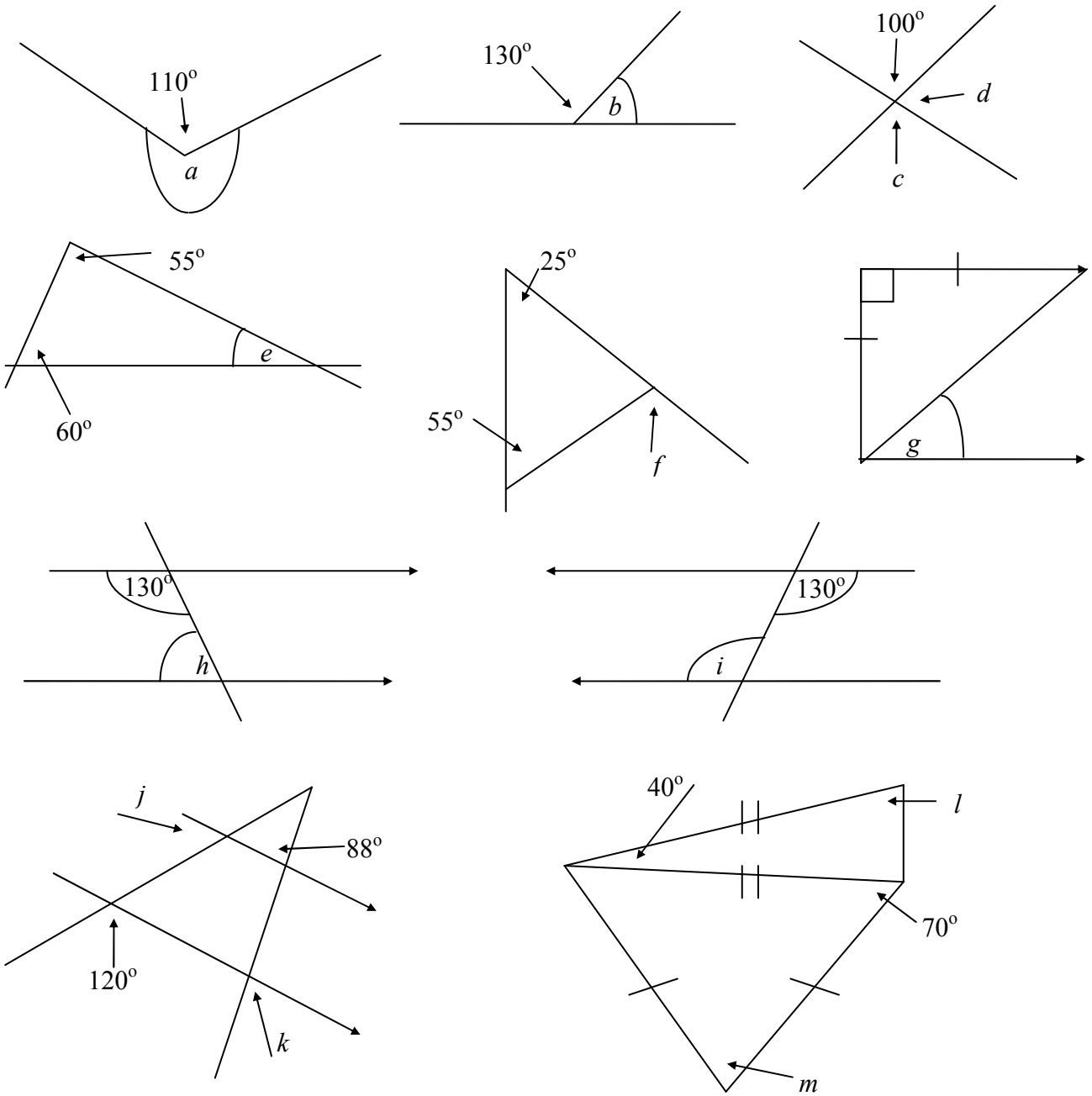

3. Calculate the areas, in  $\text{cm}^2$ , of the following shapes.

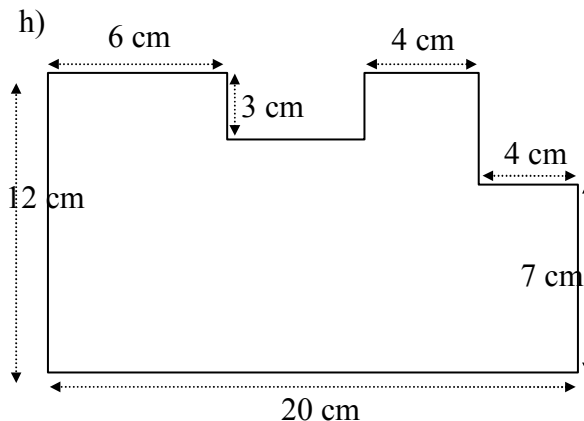
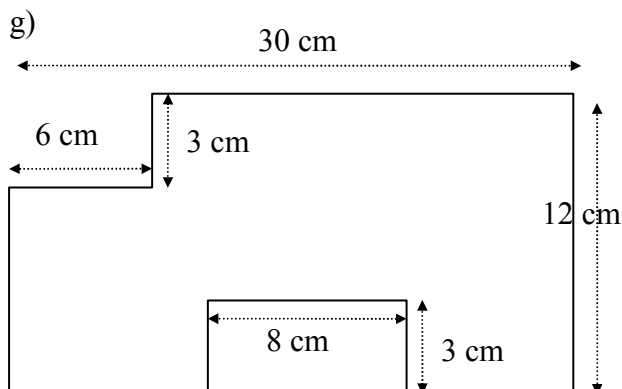
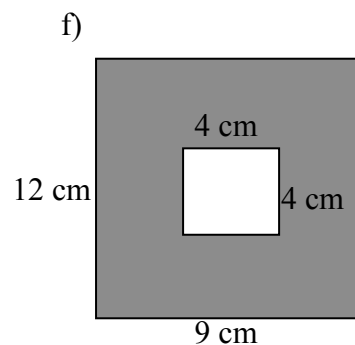
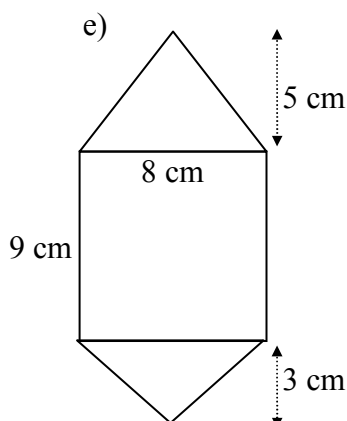
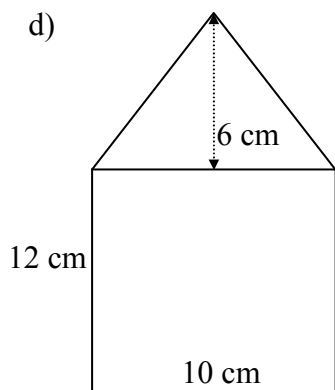
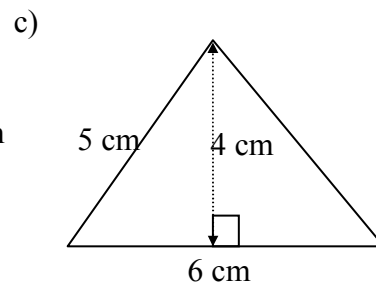
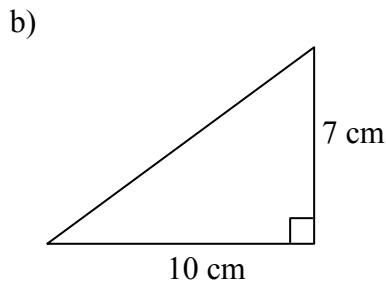
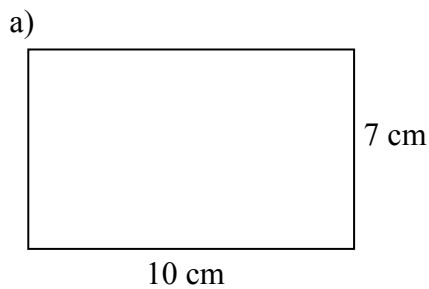

4. **On graph paper, using a scale of 1 cm to 1 unit on both axes**, draw a set of axes with both  $x$  and  $y$  from  $-8$  to  $+8$ .

i) Plot the points  $A(2, 1)$ ,  $B(4, 1)$  and  $C(4, 3)$  and draw the triangle  $ABC$ .

ii) Reflect the triangle  $ABC$  in the  $y$ -axis. Label the new triangle 1.

iii) Draw the line  $y = x$  and reflect the triangle  $ABC$  in the line. Label the new triangle 2.

iv) Draw the line  $x + y = 2$  and reflect the triangle  $ABC$  in the line. Label the new triangle 3.

5. **On graph paper, using a scale of 1 cm to 1 unit on both axes**, draw a set of axes with both  $x$  and  $y$  from  $-8$  to  $+8$ .

i) Plot the points  $A(5, 1)$ ,  $B(6, 2)$  and  $C(2, 1)$  and draw the triangle  $ABC$ .

ii) Draw the line  $x = 1$  and reflect the triangle  $ABC$  in the line. Label the new triangle 1.

iii) Draw the line  $y = 4$  and reflect the triangle  $ABC$  in the line. Label the new triangle 2.

iv) Draw the line  $y = x$  and reflect the triangle  $ABC$  in the line. Label the new triangle 3.

### **PROBABILITY.**

1. A black die and a red die are rolled at the same time and the total score is noted.

a) Copy and complete the table to show ALL the possible scores.

		BLACK					
		1	2	3	4	5	6
RED	1	2	3	4	5	6	7
	2						
	3						
	4						
	5						
	6						

b) What is the probability of getting a TOTAL of 9 on the two dice ?

c) What is the probability that the number on the black die is LESS than the number on the red die ?

2. The Queen of Hearts is taken from a pack of cards and not replaced. Find the probability that the next card is:

a) another Queen,  
c) the Ace of Hearts,

b) another Heart,  
d) the Six of Diamonds.

3. Jane and Sarah each select a number between 1 and 5 at random.

a) What is the probability that Jane selects an EVEN number?

b) Draw a table to illustrate ALL of the possible choices and hence work out the probability that Jane and Sarah select the SAME number.

4. Three fair coins are tossed at the same time.

a) List all the ways in which they can land; e.g. HEAD, HEAD, HEAD.  
HEAD, HEAD, TAIL etc.

b) Find the probability of getting (i) 3 heads, (ii) 2 heads and a tail (in any order)

5. A four sided die with faces numbered 1 to 4 and a six sided die with faces numbered 1 to 6 are rolled together. The *score* is the sum of the two numbers showing on the dice.

a) Draw a table to show ALL the possible scores.

b) What is the probability that a total of 6 is obtained ?

c) What is the probability that the number on the four sided die is higher than that showing on the six sided die ?

6. It is found that if a drawing pin is thrown, the probability that it lands '*point up*' is 0.62.

What is the probability that a drawing pin **does not** land point up ?

## ANSWERS.

### NUMBER.

1. i) a) 444, b) 3642, c) 242, d) 49, e) 375,  
f) 49590, g) 53, h) 26.5,  
ii) a) 15.88, b) 10.12, c) 14.73, d) 8.9, e) 11.84,  
f) 16.448, g) 0.65, h) 1.93.
2. a) 150, b) 1500, c) 15000, d) 150000, e) 1260, f) 1.34,  
g) 3, h) 0.30, i) 0.035523, j) 0.001.
3. a) 1, 2, 3, 4, 6, 12, b) 1, 2, 3, 4, 6, 8, 12, 24,  
c) 1, 2, 5, 10, 25, 50, d) 1, 2, 4, 5, 10, 20, 25, 50, 100,  
e) 1, 2, 4, 5, 8, 10, 20, 40.
4. a) 6, b) 2, c) 1, d) 8, e) 12.
5. a) 5, 10, 15, 20, 25, b) 8, 16, 24, 32, 40.
6. a)  $2 \times 2 \times 3 \times 5$ , b)  $2 \times 5 \times 5$ , c)  $2 \times 2 \times 2 \times 5$ , d)  $2 \times 2 \times 2 \times 3 \times 5$ ,  
e)  $2 \times 2 \times 2 \times 2 \times 5 \times 5$ .
7. a) 8.019, 8.109, 8.901, 8.91, b) 0.016, 0.106, 0.16, 0.61,  
c) 0.561, 5.061, 5.601, 5.61, 56.1, d) -9, -7, -3, 2, 5,  
e) -8, -4, 0, 1, 3, 5.
8. a) -9, b) 9, c) 3, d) 28, e) -66, f) 32,  
g) 18, h) 27, i) 15, j) 18, k) 13, l) -5,  
m) 21, n) 0, o) 36, p) 26.
9. a)  $\frac{1}{2}$ , b)  $\frac{1}{3}$ , c)  $\frac{1}{4}$ , d)  $\frac{2}{3}$ , e)  $\frac{3}{4}$ , f)  $\frac{3}{5}$ , g)  $\frac{3}{20}$ , h)  $\frac{2}{5}$ , i)  $\frac{5}{6}$ , j)  $\frac{2}{3}$ .
10. a)  $\frac{3}{2}$ , b)  $\frac{7}{3}$ , c)  $\frac{17}{5}$ , d)  $\frac{37}{9}$ , e)  $\frac{43}{4}$ , f)  $\frac{51}{7}$ .
11. a)  $\frac{13}{20}$ , b)  $\frac{3}{8}$ , c)  $\frac{31}{15}$  or  $2\frac{1}{15}$ , d)  $\frac{2}{5}$  or  $\frac{6}{15}$ , e)  $\frac{8}{33}$  or  $\frac{24}{99}$ , f) 4.
12. a) £20, b) £12, c) £12, d) £45, e) £2, f) £10, g) £24, h) £96, i) £24, j) £28, k) £11, l) £6.60.
13. a) 60%, b) 80%, c) 60%, d) 30%, e) 40%, f) 30%.
14. a) i) 6.589, ii) 22.949, iii) 0.006, iv) 1.160,  
b) i) 8510, ii) 0.00528, iii) 599, iv) 92000.

### ALGEBRA.

1. a)  $2^4$ , b)  $2^2$ , c)  $2^6$ , d)  $2^1$ , e)  $2^8$ .
2.  $3^4$ .
3. a) 11, b) 13, c) 33, d) 25, e) 36, f) 48,  
g) 9, h) 9, i) 6, j) 0, k) 9, l) 0,  
m) 9, n) 33, o) 147, p) -7.
4. a)  $9a + 7b$ , b)  $6a + 12b$ , c)  $15a + 5b + 2$ , d)  $5a - 2b + 8$ ,  
e)  $-5a + 14b$ , f)  $5ab - a$ , g)  $2ab + 3a - 4$ ,  
h)  $4a^2$ , i)  $5a^2 + 4b^2 + 4a$ , j)  $3a^2 + 4a + 4$ .
5. a)  $10a$ , b)  $30a$ , c)  $6a^2$ , d)  $6a^3$ , e)  $12a^3b^2$ , f)  $5a + 10$ ,  
g)  $8a + 40$ , h)  $20 + 6a$ , i)  $10 + 2a$ , j)  $12 + 5a$ , k)  $9a + 18$ , l)  $20 - 9a$ ,  
m)  $20 - 5a$ , n)  $4a - 10$ , o)  $2a + 15$ , p)  $18a - 3$ .
6. i) a)  $x = 5$ , b)  $x = 7$ , c)  $x = 8$ , d)  $x = 4$ , e)  $x = 8$ ,  
f)  $x = 2$ , g)  $x = 7$ , h)  $x = -4$ , i)  $x = 5$ , j)  $x = 14$ ,  
k)  $x = -4$ , l)  $x = 7$ , m)  $x = 10$ , n)  $x = 5$ , o)  $x = 1$ ,  
p)  $x = 5$ , q)  $x = 4$ , r)  $x = -6$ , s)  $x = 3$ , t)  $x = 2$ ,  
u)  $x = 11$ , v)  $x = 3$ , w)  $x = 4$ , x)  $x = 6$ , y)  $x = 60$ ,  
z)  $x = 4$ .
- ii) a)  $x = 7$ , b)  $x = 2$ , c)  $x = 3 \cdot 5$ , d)  $x = 7$ , e)  $x = 4$ ,

- f)  $x = 5$ ,      g)  $x = 17$ ,      h)  $x = 3$ ,      i)  $x = 10$ ,      j)  $x = 1$ ,  
k)  $x = 10$ ,      l)  $x = 1$ ,      m)  $x = -2$ ,      n)  $x = 5$ ,      o)  $x = 5$ .
10. b) 5.30 p.m. or 17:30,      c) 4.40 p.m. or 16:40,      d) 3.20 p.m. or 15:20.  
11. b) 6.00 p.m. or 18:00,      c) 20 mph,      d) 5.00 p.m. or 17:00,  
e) 3.48 p.m. or 15:48.

### **SHAPE & SPACE.**

1.  $a = 10$  cm,  $A = 36.9^\circ$ ,  $B = 58.8^\circ$ ,  $b = 6.2$  cm,  $C = 65^\circ$ .  
2.  $a = 250^\circ$ ,  $b = 50^\circ$ ,  $c = 100^\circ$ ,  $d = 80^\circ$ ,  $e = 65^\circ$ ,  $f = 80^\circ$ ,  $g = 45^\circ$ ,  $h = 50^\circ$ ,  $i = 130^\circ$ ,  
 $j = 60^\circ$ ,  $k = 88^\circ$ ,  $l = 70^\circ$ ,  $m = 40^\circ$ .  
3. a)  $70$  cm<sup>2</sup>, b)  $35$  cm<sup>2</sup>, c)  $12$  cm<sup>2</sup>, d)  $150$  cm<sup>2</sup>, e)  $104$  cm<sup>2</sup>, f)  $92$  cm<sup>2</sup>, g)  $318$  cm<sup>2</sup>,  
h)  $202$  cm<sup>2</sup>.

### **PROBABILITY.**

1. b)  $\frac{1}{9}$ ,      c)  $\frac{5}{12}$ .  
2. a)  $\frac{3}{51} = \frac{1}{17}$ ,      b)  $\frac{12}{51} = \frac{4}{17}$ ,      c)  $\frac{1}{51}$ ,      d)  $\frac{1}{51}$ .  
3. a)  $\frac{2}{5}$ ,      b)  $\frac{1}{5}$ .  
4. a) HHH, HHT, HTH, THH, TTH, THT, HTT, TTT,      b) i)  $\frac{1}{8}$ ,      ii)  $\frac{3}{8}$ .  
5. b)  $\frac{1}{6}$ ,      c)  $\frac{1}{4}$ .  
6. 0.38.

## END OF YEAR REVISION

### NUMBER.

- Do the following calculations, showing **ALL** your working in full.
  - $307 + 137$
    - $3472 + 169$
    - $386 - 144$
    - $225 - 176$
    - $25 \times 15$
    - $145 \times 342$
    - $8 \overline{)424}$
    - $16 \overline{)424}$ .
  - $12.6 + 3.28$
    - $5.8 + 4.32$
    - $21.97 - 7.24$
    - $13.5 - 4.6$
    - $7.4 \times 1.6$
    - $5.14 \times 3.2$
    - $5.2 \div 8$
    - $9.65 \div 5$ .
- Write down the answers to the following: (**Do NOT use long multiplication/division!**)
  - $15 \times 10$
  - $15 \times 100$
  - $15 \times 1000$
  - $15 \times 10000$
  - $12.6 \times 100$
  - $0.134 \times 10$
  - $300 \div 100$
  - $30 \div 100$
  - $35.523 \div 1000$
  - $0.01 \div 10$ .
- Write down all the factors of the following numbers.
  - 12,
  - 24,
  - 50,
  - 100,
  - 40.
- Find the **highest common factors** of the following pairs of numbers.
  - 6, 18,
  - 6, 20,
  - 8, 25,
  - 16, 40,
  - 24, 60.
- Write down the first 5 multiples of the number 5.
  - Write down the first 5 multiples of the number 8.
- Express each of the following numbers as a product of primes.
  - 60,
  - 50,
  - 40,
  - 120,
  - 400.
- Arrange in order of size, putting the smallest first:
  - 8.91, 8.901, 8.019, 8.109.
  - 0.16, 0.016, 0.106, 0.61.
  - 5.061, 56.1, 5.601, 0.561, 5.61.
  - 7, 5, -3, -9, 2.
  - 5, -8, -4, 1, 3, 0.
- Do the following calculations without the aid of a calculator.
  - $15 - 24$ ,
  - $-7 + 16$ ,
  - $14 + (-11)$ ,
  - $-4 \times (-7)$ ,
  - $-11 \times (6)$ ,
  - $12 + 5 \times 4$ ,
  - $10 + 4 \times 5 - 2 \times 6$ ,
  - $15 + 3 \times (16 - 14)^2$ ,
  - $5^2 - 10$ ,
  - $-3 \times (-2) + 12$ ,
  - $4 + (-3)^2$ ,
  - $4 - (-3)^2$ ,



ii) Solve the following equations.

a)  $4(x - 2) = 2(x + 3)$ ,

c)  $3(2x - 1) = 4(x + 1)$ ,

e)  $7(x - 3) = 11 - x$ ,

g)  $3(x - 1) = 2(x + 7)$ ,

i)  $2(5 + x) = x + 20$ ,

k)  $100 - 2(10 + x) = 60$ ,

m)  $10 - x = 12$ ,

o)  $10 - 3(3 - x) = 16$ .

b)  $3(2x + 4) = 4(x + 4)$ ,

d)  $4(2x + 1) = 6(x + 3)$ ,

f)  $2(x - 10) = 5 - 3x$ ,

h)  $x + 2(x + 4) = 17$ ,

j)  $3(2x + 4) + 2(3x + 2) = 28$ ,

l)  $10 - 3(3 - x) = 4$ ,

n)  $3x + 2(x + 1) = 3x + 12$ ,

**Answer questions 7) – 9) on graph paper.**

7. Draw a set of axes with  $x$  from  $-4$  to  $+4$  and  $y$  from  $-8$  to  $+10$ . Draw and label the following graphs on your axes.

a)  $x = 3$ ,

b)  $y = 4$ ,

c)  $x = -2$ ,

d)  $y = x + 4$ ,

e)  $y = 2x + 1$ .

8. Draw a set of axes with  $x$  from  $-3$  to  $+3$  and  $y$  from  $-10$  to  $+10$ . Draw and label the following graphs on your axes.

a)  $y = x + 3$ ,

b)  $y = 4 - 2x$ ,

c)  $y = 3x + 1$ ,

d)  $x + y = 6$ .

9. Draw a set of axes with  $x$  from  $-5$  to  $+8$  and  $y$  from  $-8$  to  $+10$ . Draw and label the following graphs on your axes.

a)  $x = -4$ ,

b)  $y = -3$ ,

c)  $y = x + 1$ ,

d)  $y = 2x - 1$ ,

e)  $x + y = 5$ .

**SHAPE & SPACE.**

1. Use a ruler, protractor and a compass to draw, accurately, the following shapes. Measure and write down the lengths of  $a$ , and  $b$  and the size of angles  $A$ ,  $B$ , and  $C$ .

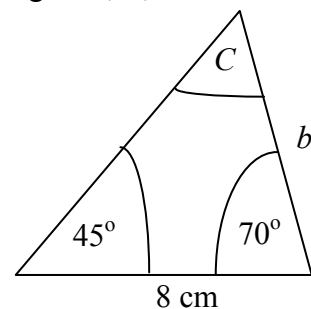
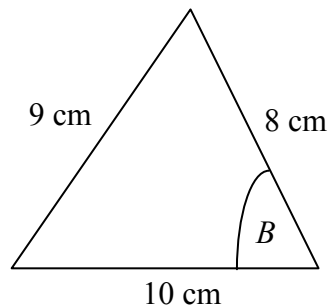
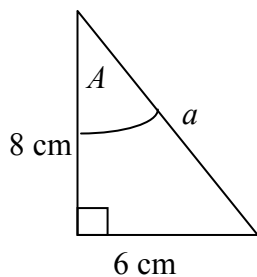

2. Find, by calculation, the angles marked with letters (DO NOT measure; **NOT to scale!**)

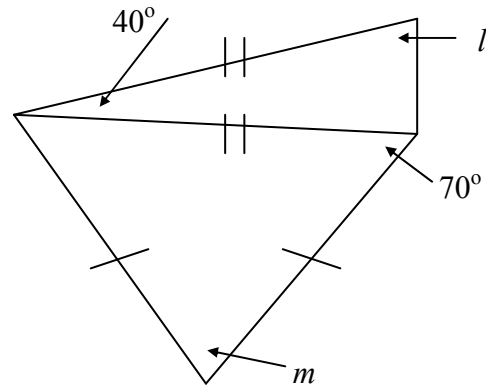
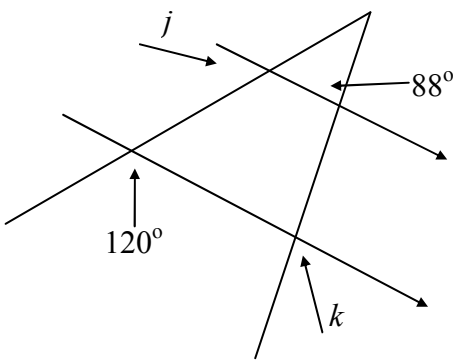
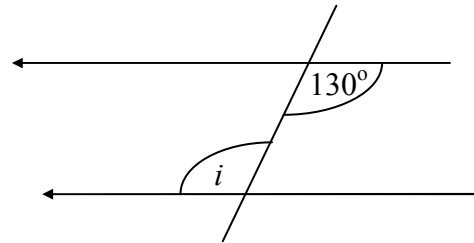
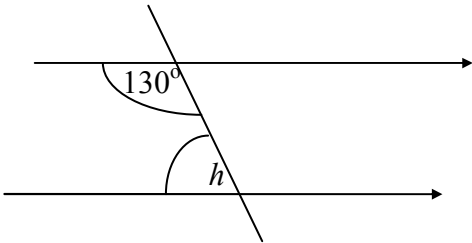
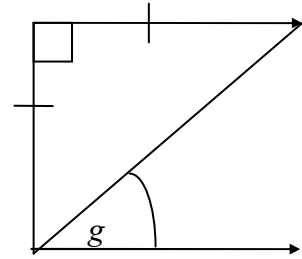
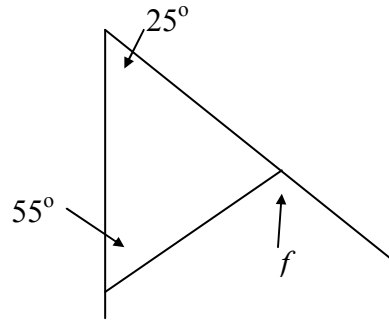
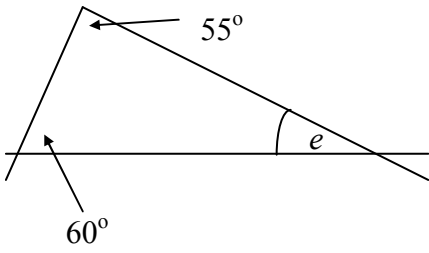
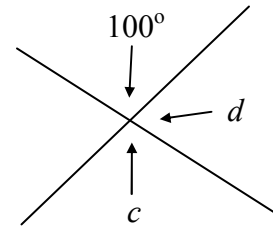
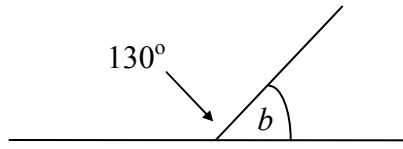
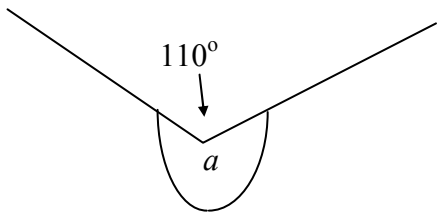

GEOMETRIC CONSTRUCTIONS.

USE A COMPASS AND A STRAIGHT EDGE ONLY (No protractors or rulers allowed!)

i) Bisect (cut into 2 equal halves) the following lines.



ii) Bisect (cut into 2 equal parts) the angles between the following lines.

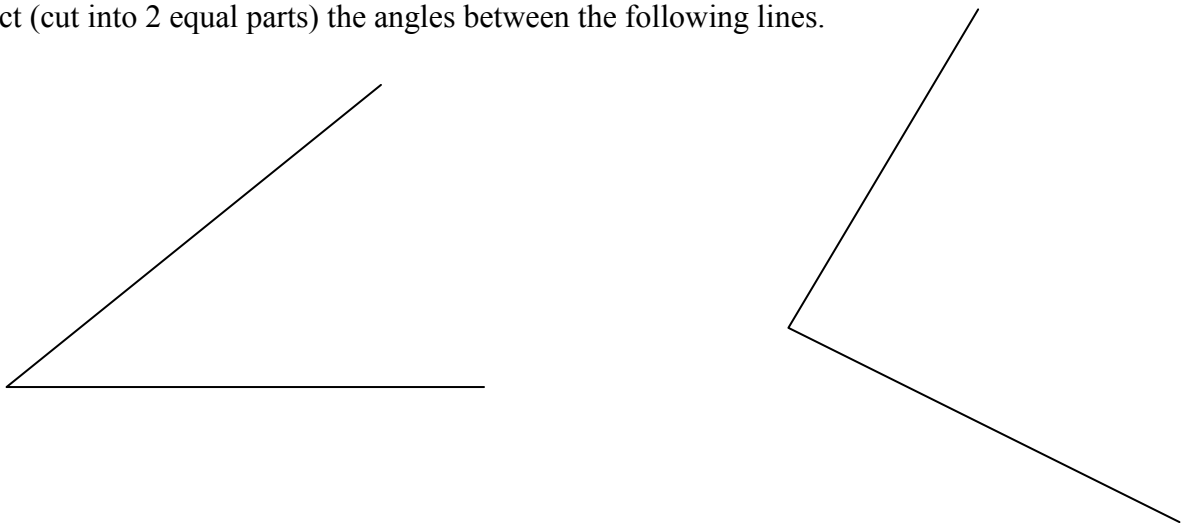

iii) Construct a line which is at right angles to the line  $AB$  and which passes through the point  $P$ .

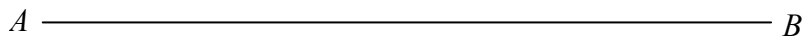

iv) Construct a line which is at right angles to the line  $CD$  and which passes through the point  $Q$ .

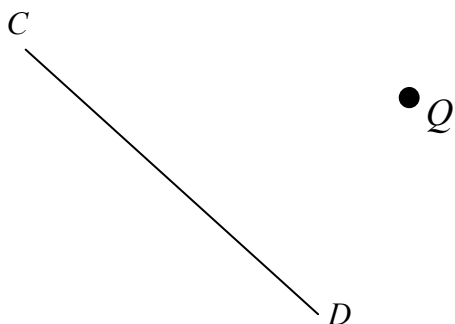

## ANSWERS.

### NUMBER.

1. i) a) 444, b) 3642, c) 242, d) 49, e) 375,  
f) 49590, g) 53, h) 26.5,  
ii) a) 15.88, b) 10.12, c) 14.73, d) 8.9, e) 11.84,  
f) 16.448, g) 0.65, h) 1.93.
2. a) 150, b) 1500, c) 15000, d) 150000, e) 1260, f) 1.34,  
g) 3, h) 0.30, i) 0.035523, j) 0.001.
3. a) 1, 2, 3, 4, 6, 12, b) 1, 2, 3, 4, 6, 8, 12, 24,  
c) 1, 2, 5, 10, 25, 50, d) 1, 2, 4, 5, 10, 20, 25, 50, 100,  
e) 1, 2, 4, 5, 8, 10, 20, 40.
4. a) 6, b) 2, c) 1, d) 8, e) 12.
5. a) 5, 10, 15, 20, 25, b) 8, 16, 24, 32, 40.
6. a)  $2 \times 2 \times 3 \times 5$ , b)  $2 \times 5 \times 5$ , c)  $2 \times 2 \times 2 \times 5$ , d)  $2 \times 2 \times 2 \times 3 \times 5$ ,  
e)  $2 \times 2 \times 2 \times 2 \times 5 \times 5$ .
7. a) 8.019, 8.109, 8.901, 8.91, b) 0.016, 0.106, 0.16, 0.61,  
c) 0.561, 5.061, 5.601, 5.61, 56.1, d) -9, -7, -3, 2, 5,  
e) -8, -4, 0, 1, 3, 5.
8. a) -9, b) 9, c) 3, d) 28, e) -66, f) 32,  
g) 18, h) 27, i) 15, j) 18, k) 13, l) -5,  
m) 21, n) 0, o) 36, p) 26.
9. a) i) 6.589, ii) 22.949, iii) 0.006, iv) 1.160,  
b) i) 8510, ii) 0.00528, iii) 599, iv) 92000.

### ALGEBRA.

1. a)  $2^4$ , b)  $2^2$ , c)  $2^6$ , d)  $2^1$ , e)  $2^8$ .
2.  $3^4$ .
3. a) 11, b) 13, c) 33, d) 25, e) 36, f) 48,  
g) 9, h) 9, i) 6, j) 0, k) 9, l) 0,  
m) 9, n) 33, o) 147, p) -7.
4. a)  $9a + 7b$ , b)  $6a + 12b$ , c)  $15a + 5b + 2$ , d)  $5a - 2b + 8$ ,  
e)  $-5a + 14b$ , f)  $5ab - a$ , g)  $2ab + 3a - 4$ ,  
h)  $4a^2$ , i)  $5a^2 + 4b^2 + 4a$ , j)  $3a^2 + 4a + 4$ .
5. a)  $10a$ , b)  $30a$ , c)  $6a^2$ , d)  $6a^3$ , e)  $12a^3b^2$ , f)  $5a + 10$ ,  
g)  $8a + 40$ , h)  $20 + 6a$ , i)  $10 + 2a$ , j)  $12 + 5a$ , k)  $9a + 18$ , l)  $20 - 9a$ ,  
m)  $20 - 5a$ , n)  $4a - 10$ , o)  $2a + 15$ , p)  $18a - 3$ .
6. i) a)  $x = 5$ , b)  $x = 7$ , c)  $x = 8$ , d)  $x = 4$ , e)  $x = 8$ ,  
f)  $x = 2$ , g)  $x = 7$ , h)  $x = -4$ , i)  $x = 5$ , j)  $x = 14$ ,  
k)  $x = -4$ , l)  $x = 7$ , m)  $x = 10$ , n)  $x = 5$ , o)  $x = 1$ ,  
p)  $x = 5$ , q)  $x = 4$ , r)  $x = -6$ , s)  $x = 3$ , t)  $x = 2$ ,  
u)  $x = 11$ , v)  $x = 3$ , w)  $x = 4$ , x)  $x = 6$ , y)  $x = 60$ ,  
z)  $x = 4$ .
- ii) a)  $x = 7$ , b)  $x = 2$ , c)  $x = 3 \cdot 5$ , d)  $x = 7$ , e)  $x = 4$ ,  
f)  $x = 5$ , g)  $x = 17$ , h)  $x = 3$ , i)  $x = 10$ , j)  $x = 1$ ,  
k)  $x = 10$ , l)  $x = 1$ , m)  $x = -2$ , n)  $x = 5$ , o)  $x = 5$ .

### SHAPE & SPACE.

1.  $a = 10$  cm,  $A = 36.9^\circ$ ,  $B = 58.8^\circ$ ,  $b = 6.2$  cm,  $C = 65^\circ$ .
2.  $a = 250^\circ$ ,  $b = 50^\circ$ ,  $c = 100^\circ$ ,  $d = 80^\circ$ ,  $e = 65^\circ$ ,  $f = 80^\circ$ ,  $g = 45^\circ$ ,  $h = 50^\circ$ ,  $i = 130^\circ$ ,  
 $j = 60^\circ$ ,  $k = 88^\circ$ ,  $l = 70^\circ$ ,  $m = 40^\circ$ .

# REVISION SUPPLEMENT

1. Find, by calculation, the angles marked with letters (DO NOT measure; **NOT to scale!**)

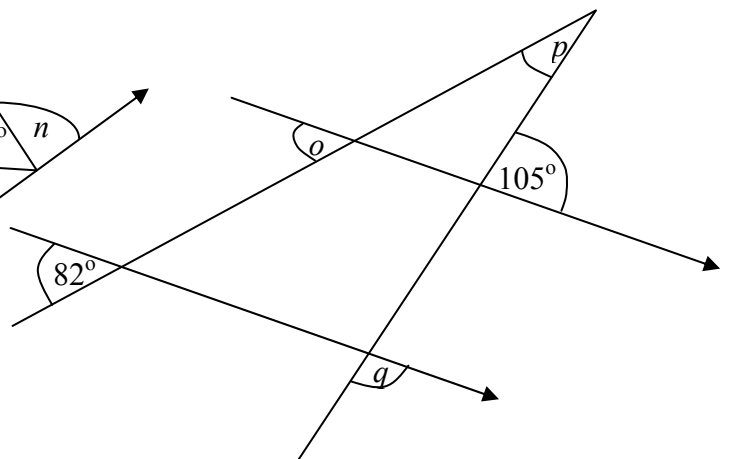
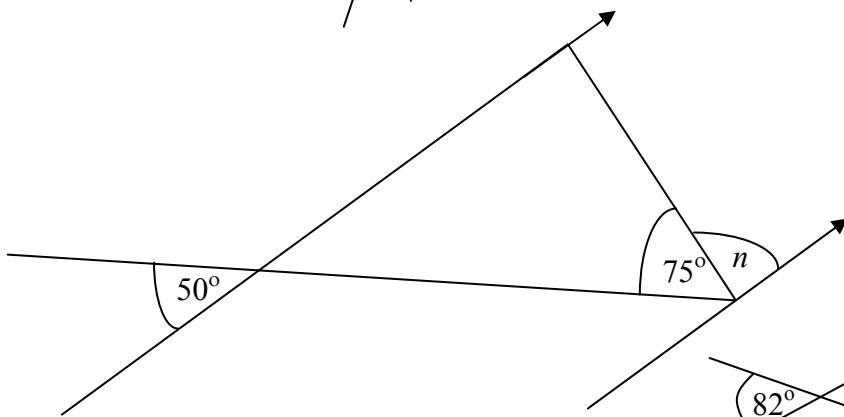
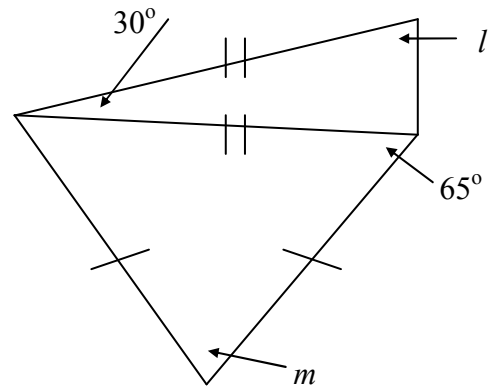
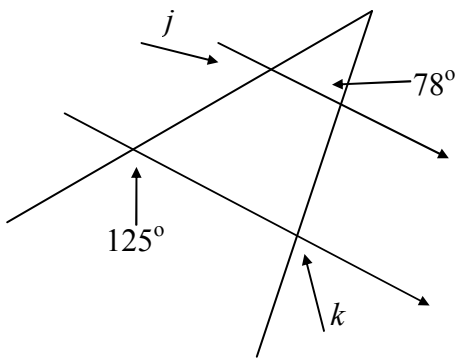
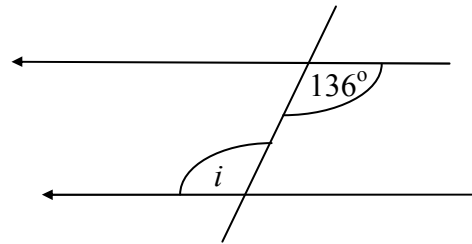
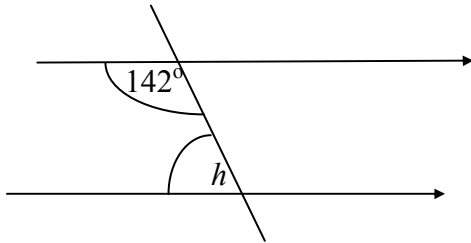
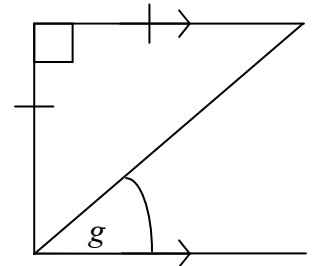
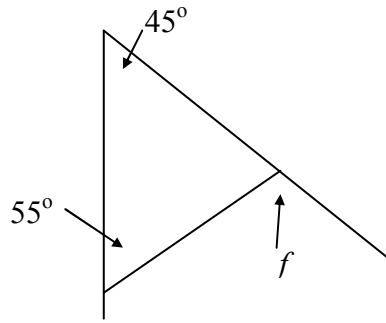
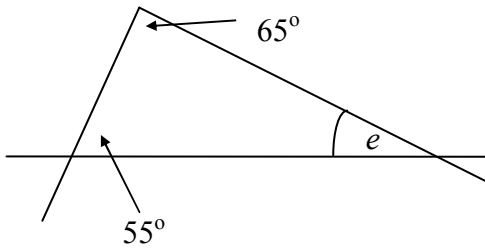
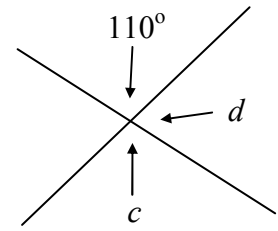
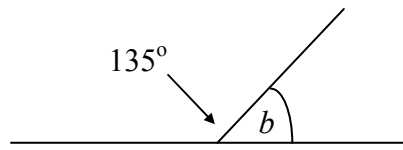
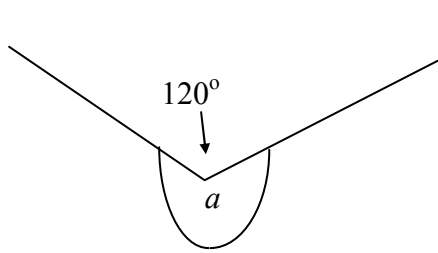

2. The diagram shows a square with three of its vertices on the sides of an equilateral triangle  $ABC$ . Find the angles marked  $a$  and  $b$ .

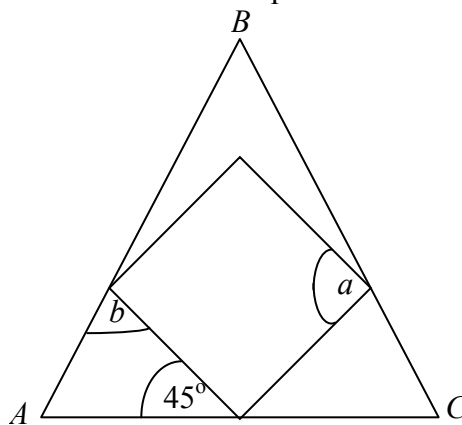

3. The angles inside a triangle add up to  $180^\circ$ .  
The angles inside any quadrilateral add up to  $360^\circ$ .

What do the angles inside a hexagon add up to? Explain your answer.

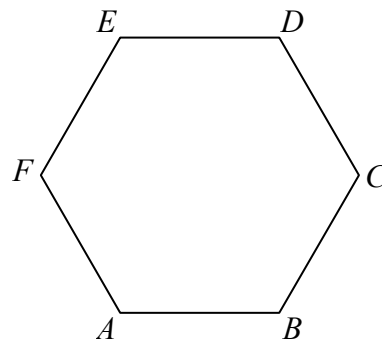

4. Write down the size of the angles marked  $x$ ,  $y$  in the following diagrams.

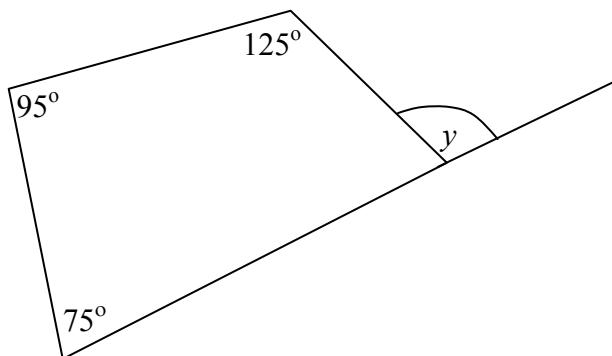
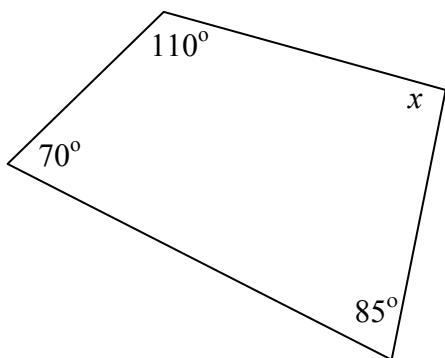

5. GEOMETRIC CONSTRUCTIONS.

USE A COMPASS AND A STRAIGHT EDGE ONLY (No protractors or rulers allowed!)

i) Bisect (cut into 2 equal halves) the following lines.

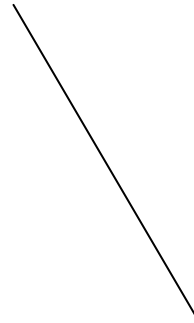

ii) Bisect (cut into 2 equal parts) the angles between the following lines.

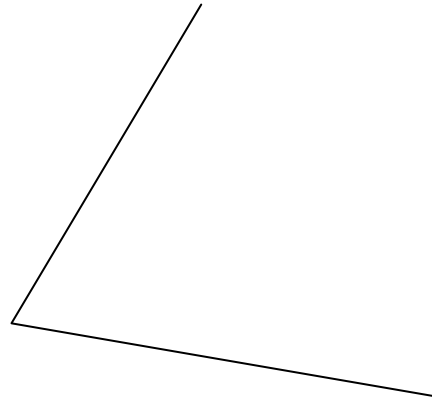
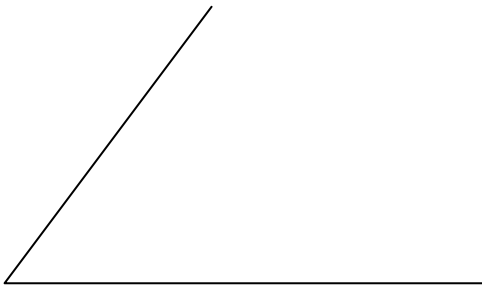

iii) Construct a line which is at right angles to the line  $AB$  and which passes through the point  $P$ .

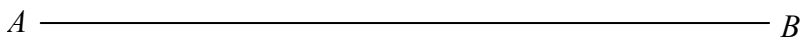



11. Simplify the following expressions, where possible.

a)  $5x + 2x$ ,

b)  $2x - 2$ ,

c)  $4a + b - 2a$ ,

d)  $5a^2 + a$ ,

e)  $3x^2 + 2x^2 - 4x^2$ ,

f)  $a + 3b - 2a$ ,

g)  $3a - 7a$ ,

h)  $x + 5x - 3x$ ,

i)  $12a - 3a - 5a$ ,

j)  $3x^2 - 5x + 4x - 2$ ,

k)  $7a^2 + 9a - 3a + 2$ ,

l)  $x^2 + 6x - 6x + 36$ ,

m)  $4a^2 - 5a + 2a - 5$ ,

n)  $10ab + 3a + 5b - 6ab + ba$ ,

o)  $ab + 3a^2 + 5b - 2a^2 - ba$ ,

p)  $11a^2 + 3a + 5b + 6ab - a^2 + 5a - 5b$ ,

q)  $8a^2b + 3a^2 + 5a^2b - 6ab^2 - a^2b + 5a^2$ ,

r)  $8ab^2 + 3a^2b - 5ab^2 + 6ab + a^2b + 5ba$ ,

s)  $ab - 3ba + 5ab^2 + 6b^2 + b^2a + 5ba$ .

12. Simplify the following.

a)  $6 \times 3a$ ,

b)  $12 \times 4a$ ,

c)  $3a \times 4a$ ,

d)  $3a \times 4a^2$ ,

e)  $3a^2b \times 2ab$ ,

f)  $4(a + 3)$ ,

g)  $5(2a + 9)$ ,

h)  $3(10 + a) + 2a$ ,

i)  $3(5 - a) + 5a$ ,

j)  $2(3 + a) + 4(2 + a)$ ,

k)  $2(2a - 6) + 3a$ ,

l)  $3(5 - 2a) + 2 + 3a$ .

13. Solve the following equations for  $x$ .

a)  $5x + 7 = 3x + 25$ ,

b)  $7x - 3 = 4x + 18$ ,

c)  $3x + 7 = 9x - 17$ ,

**ANSWERS.**

1.  $a = 240^\circ$ ,  $b = 45^\circ$ ,  $c = 110^\circ$ ,  $d = 70^\circ$ ,  $e = 60^\circ$ ,  $f = 80^\circ$ ,  $g = 45^\circ$ ,  $h = 38^\circ$ ,  $i = 136^\circ$ ,  
 $j = 55^\circ$ ,  $k = 78^\circ$ ,  $l = 75^\circ$ ,  $m = 50^\circ$ ,  $n = 55^\circ$ ,  $o = 82^\circ$ ,  $p = 23^\circ$ ,  $q = 75^\circ$ .
2.  $a = 90^\circ$ ,  $b = 75^\circ$ .
3.  $4 \times 180^\circ = 720^\circ$ .
4.  $x = 95^\circ$ ,  $y = 115^\circ$ .
9. a) i) 16.589, ii) 2.947, iii) 0.057, iv) 1.160,  
b) i) 9510, ii) 0.0538, iii) 699, iv) 93000.
10. a) 8, b) 9, c) 24, d) 13, e) 12, f) 18,  
g) 2, h) 16, i) 6, j) -2, k) -2, l) 0,  
m) 8, n) 20, o) 75, p) -5.
11. a)  $7x$ , b)  $2x - 2$ , c)  $2a + b$ , d)  $5a^2 + a$ ,  
e)  $x^2$ , f)  $3b - a$  or  $-a + 3b$ , g)  $-4a$ , h)  $3x$ ,  
i)  $4a$ , j)  $3x^2 - x - 2$ , k)  $7a^2 + 6a + 2$ , l)  $x^2 + 36$ ,  
m)  $4a^2 - 3a - 5$ , n)  $5ab + 3a + 5b$ , o)  $a^2 + 5b$ , p)  $10a^2 + 8a + 6ab$ ,  
q)  $12a^2b + 8a^2 - 6ab^2$ , r)  $3ab^2 + 4a^2b + 11ab$ .
12. a)  $18a$ , b)  $48a$ , c)  $12a^2$ , d)  $12a^3$ , e)  $6a^3b^2$ , f)  $4a + 12$ ,  
g)  $10a + 45$ , h)  $30 + 5a$ , i)  $15 + 2a$ , j)  $14 + 6a$ , k)  $7a - 12$ , l)  $17 - 3a$ .
13. a)  $x = 9$ , b)  $x = 7$ , c)  $x = 4$ ,

EXAM

MATHEMATICS  $1\frac{1}{2}$  hours

WRITE YOUR ANSWERS, INCLUDING ROUGH WORKING, ON THESE SHEETS  
CALCULATORS NOT ALLOWED

NAME: \_\_\_\_\_

FORM: \_\_\_\_\_

1. Do the following calculations, showing ALL necessary working.

a)  $36 \times 18$

.....  
.....  
.....  
.....  
.....  
.....  
.....  
.....

b)  $13.6 + 3.57$

.....  
.....  
.....  
.....  
.....  
.....  
.....  
.....

c)  $520 \div 8$

.....  
.....  
.....  
.....  
.....  
.....  
.....  
.....

d)  $3.2 \times 8.4$

.....  
.....  
.....  
.....  
.....  
.....  
.....  
.....

2. Write down the answers to the following.

a)  $12 \times 100$  .....

b)  $12.6 \times 1000$  .....

c)  $8.21 \div 1000$  .....

3. Find the **Highest Common Factor** of 18 and 42.

.....  
.....  
.....  
.....

4. Arrange in order of size, putting the smallest first.

a) 4.1, 4.01, 4.12, 4.102

.....  
.....  
.....  
.....

b) 7, 9, -5, -7, 0.

.....  
.....  
.....  
.....

5. Work out the values of the following.

a)  $10 + 3 \times 5$

.....  
.....  
.....  
.....

b)  $-6 + 16$

.....  
.....  
.....  
.....

c)  $(-3) \times (-4)$

.....  
.....  
.....  
.....

d)  $4^3 - 4 \times 5$

.....  
.....  
.....  
.....

e)  $3 \times 2 + 5 \times (12 - 3 \times 4)$ .

.....  
.....  
.....  
.....

6. Cancel the following fractions down to their simplest form.

a)  $\frac{18}{24}$  .....

.....

b)  $\frac{16}{40}$  .....

.....

c)  $\frac{28}{56}$  .....

.....

7. Work out the following.

a)  $\frac{2}{5} + \frac{1}{3}$  .....

.....

b)  $\frac{2}{5} \times \frac{5}{6}$  .....

.....

c)  $2\frac{1}{3} \times 3\frac{1}{4}$  .....

.....

.....

d)  $3\frac{2}{3} + 2\frac{3}{4}$  .....

.....

.....

.....

8. a) Write 6.287 to
- i) 1 decimal place .....
  - ii) 2 decimal places .....
  - iii) 1 significant figure .....
  - iv) 2 significant figures .....
- b) Write 254 600 to
- i) 1 significant figure .....
  - ii) 2 significant figures .....
- c) Write 0.02158 to
- i) 2 decimal places .....
  - ii) 1 significant figure .....
  - iii) 2 significant figures .....

9. Simplify the following.
- a)  $6a + 3b + 12a - 6b$  .....
  - b)  $3a^2 + 4ab + 6a^2 + 5ab$  .....
  - c)  $8 \times 3a$  .....
  - d)  $4a^2 \times 5a$  .....
  - e)  $5a + 5(2a - 2)$  .....
- .....

10. Solve the following equations.
- a)  $4x + 5 = 33$
- .....
- .....
- .....
- b)  $6x - 11 = 31$
- .....
- .....
- .....

c)  $4(x - 7) = 20$

.....  
.....  
.....

d)  $5x - 3 = 3x + 11$

.....  
.....  
.....

e)  $4(x - 2) + 3(x + 5) = 42$ .

.....  
.....  
.....

11. Given that  $a = 3$        $b = -2$       and       $c = 4$ , work out the values of

a)  $4a + b$

.....  
.....  
.....

b)  $3a + 2b$

.....  
.....  
.....

c)  $c^2 + b^2$

.....  
.....  
.....

d)  $ab + bc$

.....  
.....  
.....

12. Find by calculation (NOT by measuring!), the angles labelled  $a$ ,  $b$ ,  $c$  and  $d$ .

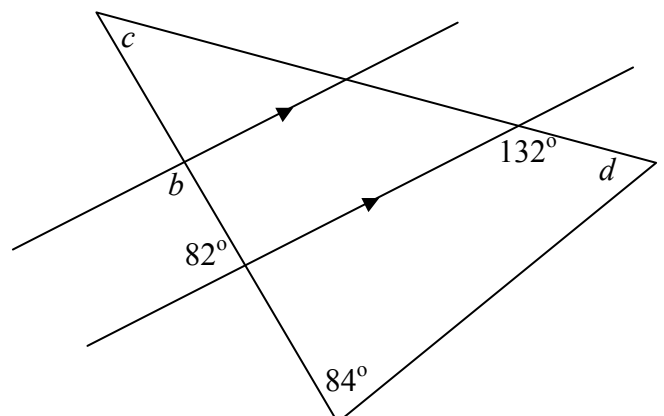
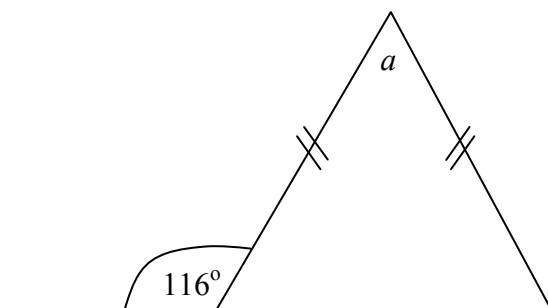

$a =$  .....

$b =$  .....

$c =$  .....

$d =$  .....

13.

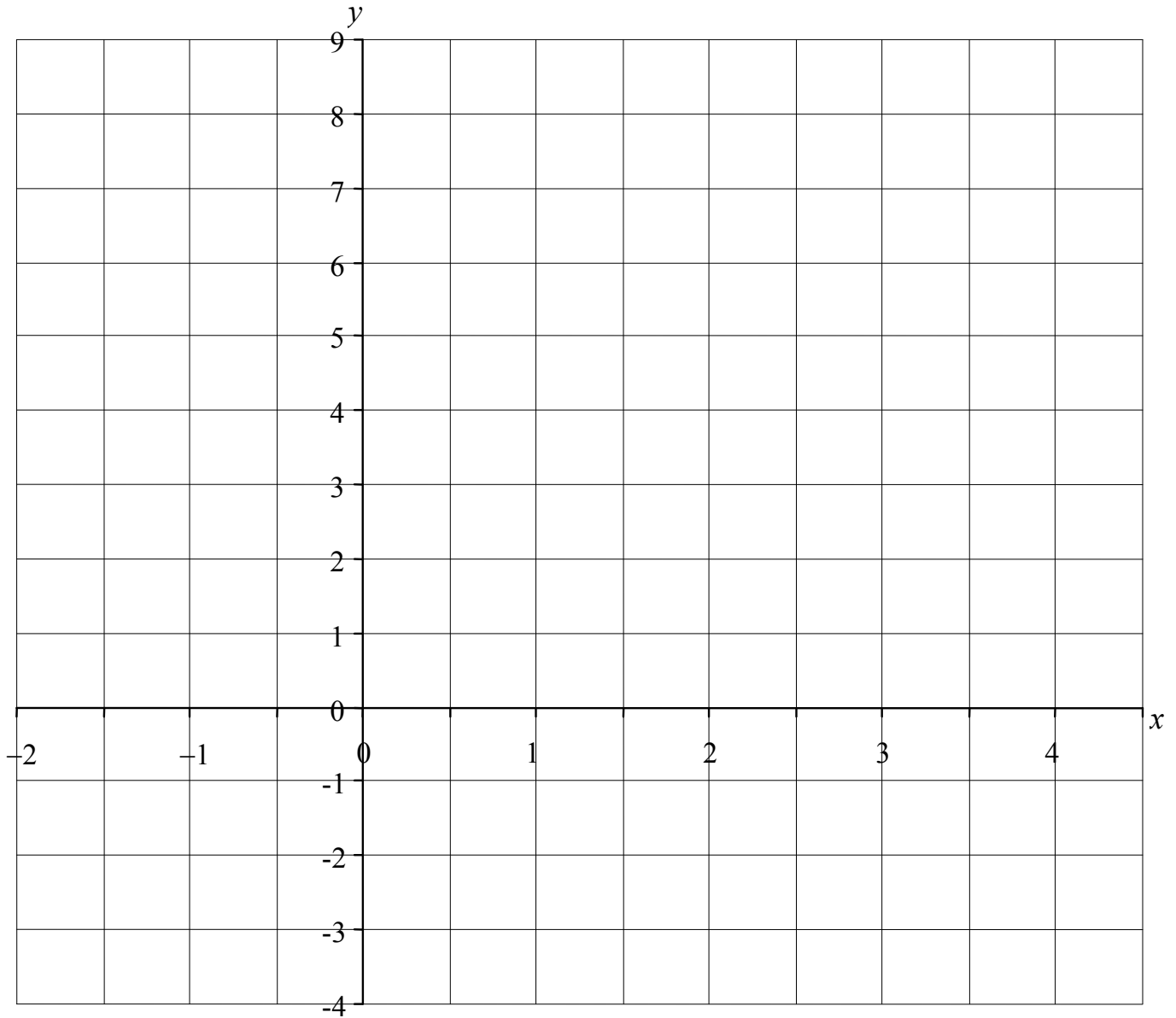

Using the axes above, draw and label the following graphs

a)  $x = -1,$

b)  $y = -2,$

c)  $y = x + 3,$

d)  $x + y = 4,$

e)  $y = 8 - 2x.$

14. The two spinners shown are spun together.

a) Complete the table below to show all the possible scores obtained by adding the two numbers on the spinners.

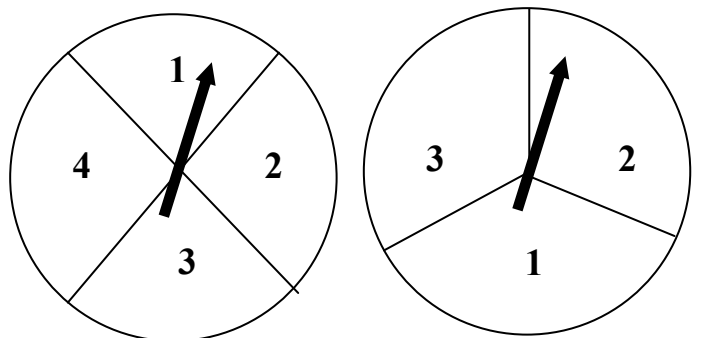

	<b>1</b>	<b>2</b>	<b>3</b>	<b>4</b>
<b>1</b>	2	3	4	5
<b>2</b>				
<b>3</b>				

b) Find the probability that the TOTAL score on the two spinners is 4.

.....

.....

c) Find the probability that at least one of the spinners shows a 1.

.....

.....

15. Two towns, *A* and *B*, are 80 km apart. Samantha leaves town *A* at 12:00 p.m. and travels towards *B*. She travels at 20 km/h for  $1\frac{1}{2}$  hours, and then rests for  $\frac{1}{2}$  hour. She then continues at 20 km/h for another hour before resting again for 1 hour. She then takes exactly 1 hour to complete her journey.

a) On the axes below, draw the graph of Samantha's journey between towns *A* and *B*.

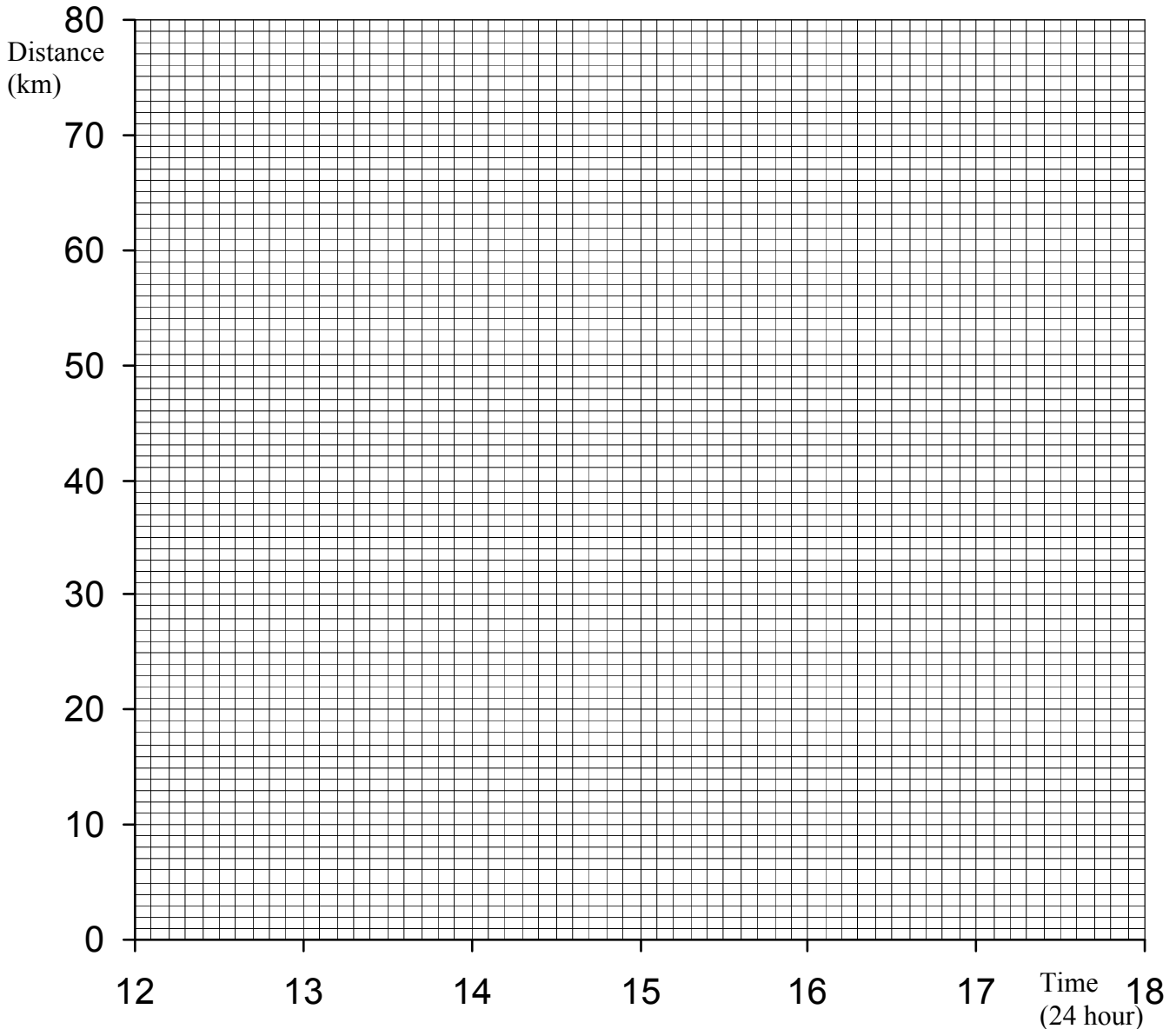

b) What time does Samantha arrive at town  $B$ ?

.....  
.....

c) How far does Samantha travel in the last hour of her journey?

.....  
.....

Billy leaves town  $B$  at 1 p.m. and travels towards town  $A$  at a constant 20 km/h.

Draw Billy's journey on the above graph.

d) At what time did Billy arrive home?

.....  
.....

e) At what time did Samantha and Billy pass each other?

.....  
.....

16. Find the areas of the following shapes.

a)

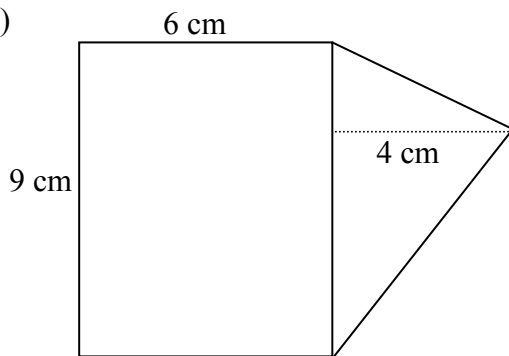

.....  
.....  
.....  
.....  
.....  
.....

b)

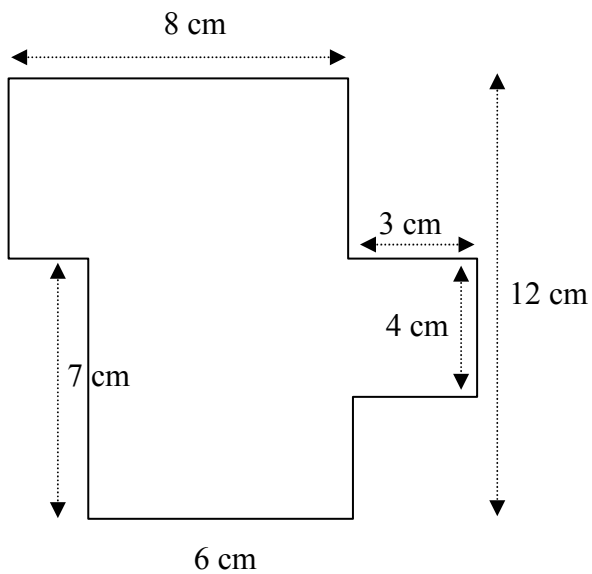

.....  
.....  
.....  
.....  
.....  
.....  
.....  
.....  
.....  
.....

## REVISION SHEET 1.

1. Change the following as indicated.

- |                 |                 |                     |                  |
|-----------------|-----------------|---------------------|------------------|
| a) 35 cm to m,  | b) 2 km to m,   | c) 2 km to cm,      | d) 1020 g to kg, |
| e) 350 cm to m, | f) 4.5 kg to g, | g) 50 000 cm to km, | h) 600 g to kg,  |
| i) 1.5 m to cm, | j) 5 km to m,   | k) 700 cm to m,     | l) 3.25 kg to g. |

2. Change the following as indicated.

- |                         |                          |                        |                        |
|-------------------------|--------------------------|------------------------|------------------------|
| a) 15 cm to inches,     | b) 25 cm to inches,      | c) 15 inches to cm,    | d) 25 inches to cm,    |
| e) 5 kg to pounds       | f) 12 kg to pounds,      | g) 5 pounds to kg,     | h) 12 pounds to kg,    |
| i) 10 miles to km,      | j) 17 miles to km,       | k) 10 km to miles,     | l) 17 km to miles,     |
| m) 3 gallons to litres, | n) 30 litres to gallons, | o) 12 pints to litres, | p) 4 gallons to pints. |

3. The scale of a map is 1:1000.

- a) Find the actual length in metres represented on the map by 15 cm.  
b) The distance between two towns is 250 m. How far apart will the two points be on the map?

4. The scale of a map is 1 : 20 000, find,

- a) the actual distance in metres represented by 3.5 cm on the map,  
b) the distance on the map which will represent an actual distance of 4 km.

5. A map is drawn to a scale of 1:25 000, find,

- a) the actual distance in km represented by 19 cm on the map.  
b) the distance on the map which will represent an actual distance of 3 km.

6. Put the following numbers into standard form,

- |            |             |          |           |               |             |
|------------|-------------|----------|-----------|---------------|-------------|
| a) 15,     | b) 99,      | c) 0.16, | d) 0.002, | e) 0.0034217, | f) 0.00111, |
| g) 0.5,    | h) 5210,    | i) 521,  | j) 52.1,  | k) 5.21,      | l) 0.521,   |
| m) 0.0521, | n) 0.00521. |          |           |               |             |

7. Use your calculator to work out the following.

**Give your answers in standard form.**

- |   |   |   |
|---|---|---|
| a) $(3 \times 10^7) + (1.4 \times 10^5)$ ,      | b) $(9.9 \times 10^6) \times (2 \times 10^{-3})$ ,  | c) $\frac{(3 \times 10^2)}{(3 \times 10^{-3})}$   |
| d) $(4.25 \times 10^6) - (3.456 \times 10^4)$ , | e) $(7.29 \times 10^{12}) \div (3.5 \times 10^8)$ , | f) $\frac{(36 \times 10^4)}{(8.5 \times 10^3)}$ . |

8. A ship sails 8 km on a bearing of  $080^{\circ}\text{N}$  and then a further 6 km on a bearing of  $150^{\circ}\text{N}$ .
- a) How far away is the ship from its' starting point ?
- b) Upon what bearing must the ship sail in order to return to its' starting point ?

9. A ship sails 7 km on a bearing of  $160^{\circ}\text{N}$  and then a further 10 km on a bearing of  $230^{\circ}\text{N}$ .
- a) How far away is the ship from its' starting point ?

- b) Upon what bearing must the ship must sail in order to return to its' starting point ?

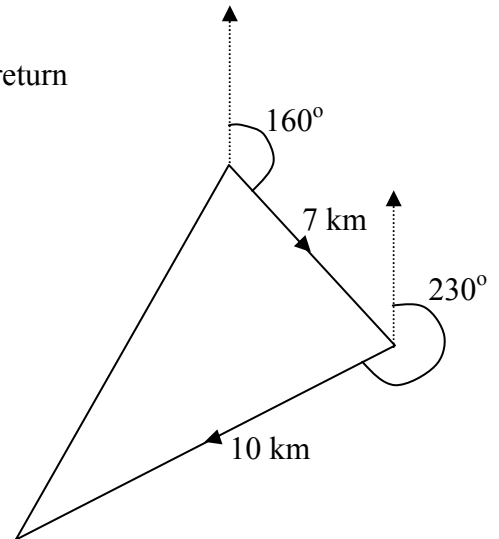

## HALF-TERMLY TEST 1.

1. Copy and complete the following table to show metric and imperial conversions.

Metric	Imperial
..... cm	1 inch
..... km	1 mile
1 kg	..... pounds
..... litres	1 gallon

2. Change the following as indicated.

a) 5 inches to cm,      b) 8 km to miles,      c) 17 kg to pounds,      d) 20 litres to gallons.

3. The scale of a map is 1:5000.

a) Find the actual length in metres represented on the map by 15 cm.

b) The distance between two towns is 4.5 km. How far apart will the two towns be on the map?

4. Write the following numbers in standard form.

a) 65,      b) 6250,      c) 0.0026,      d) 6.52,      e) 1325000,      f) 0.0205.

5. Use your calculator to work out the following. **Give your answers in standard form.**

a)  $(6 \times 10^8) + (3.4 \times 10^6)$ ,      b)  $\frac{(8 \times 10^4)}{(4 \times 10^{-2})}$ .

6. A ship sails 8 km on a bearing of  $150^\circ\text{N}$  and then a further 10 km on a bearing of  $235^\circ\text{N}$ .

a) Make an accurate scale diagram of the ship's journey using a scale of 1 cm to 1 km.

b) By making accurate measurements on your diagram, find

i) how far away the ship is from its' starting point ?

ii) the bearing upon which the ship must sail in order to return to its' starting point ?

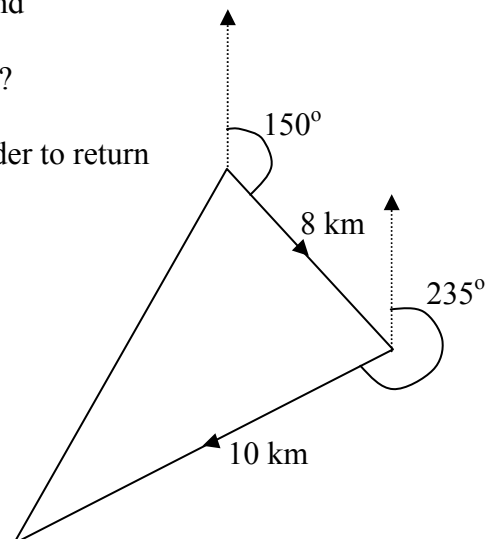

## YEAR 8; TIER A:– JUNE REVISION

### NUMBER.

1. Change the following as indicated.  
a) 35 cm to m,      b) 2 km to m,      c) 2 km to cm,      d) 1020 g to kg,  
e) 350 cm to m,      f) 4.5 kg to g,      g) 50 000 cm to km,      h) 600 g to kg,  
i) 1.5 m to cm,      j) 5 km to m,      k) 700 cm to m,      l) 3.25 kg to g.
  
2. Change the following as indicated.  
a) 15 cm to inches,      b) 25 cm to inches,      c) 15 inches to cm,      d) 25 inches to cm,  
e) 5 kg to pounds      f) 12 kg to pounds,      g) 5 pounds to kg,      h) 12 pounds to kg,  
i) 10 miles to km,      j) 17 miles to km,      k) 10 km to miles,      l) 17 km to miles,  
m) 3 gallons to litres,      n) 30 litres to gallons,      o) 12 pints to litres,      p) 4 gallons to pints.
  
3. The scale of a map is 1:1000.  
a) Find the actual length in metres represented on the map by 15 cm.  
b) The distance between two towns is 250 m. How far apart will the two points be on the map?
  
4. The scale of a map is 1 : 20 000, find,  
a) the actual distance in metres represented by 3.5 cm on the map,  
b) the distance on the map which will represent an actual distance of 4 km.
  
5. A map is drawn to a scale of 1:25 000, find,  
a) the actual distance in km represented by 19 cm on the map.  
b) the distance on the map which will represent an actual distance of 3 km.
  
6. Write the following numbers in standard form.  
a) 35,      b) 4210,      c) 125.002,      d) 9.2,      e) 125000,      f) 8,      g) 0.025,  
h) 0.00167,      i) 10,      j) 1,      k) 251,      l)  $2^3 \times 3^2$ ,      m) 100 000.
  
7. Work out the following. **Give your answers in standard form.**  
a)  $(3 \times 10^7) + (1.4 \times 10^5)$ ,      b)  $(9.9 \times 10^6) \times (2 \times 10^{-3})$ ,      c)  $\frac{(3 \times 10^2)}{(3 \times 10^{-3})}$   
d)  $(4.25 \times 10^6) - (3.456 \times 10^4)$ ,      e)  $(7.29 \times 10^{12}) \div (3.5 \times 10^8)$ ,      f)  $\frac{(36 \times 10^4)}{(8.5 \times 10^3)}$ .
  
8. **No calculator.** Cancel the following fractions down to their simplest form.  
a)  $\frac{2}{4}$ ,      b)  $\frac{2}{6}$ ,      c)  $\frac{2}{8}$ ,      d)  $\frac{20}{30}$ ,      e)  $\frac{15}{20}$ ,      f)  $\frac{24}{40}$ ,      g)  $\frac{12}{80}$ ,      h)  $\frac{22}{55}$ ,      i)  $\frac{45}{54}$ ,      j)  $\frac{26}{39}$ .
  
9. **No calculator.** Write the following fractions in *top heavy* form.  
a)  $1\frac{1}{2}$ ,      b)  $2\frac{1}{3}$ ,      c)  $3\frac{2}{5}$ ,      d)  $4\frac{1}{9}$ ,      e)  $10\frac{3}{4}$ ,      f)  $7\frac{2}{7}$ .
  
10. **No calculator.** Work out the following, simplifying your answers.  
a)  $\frac{1}{4} + \frac{2}{5}$       b)  $\frac{5}{8} - \frac{1}{4}$       c)  $1\frac{2}{3} + \frac{2}{5}$       d)  $\frac{2}{3} \times \frac{3}{5}$       e)  $\frac{4}{9} \times \frac{6}{11}$       f)  $1\frac{3}{5} \times 2\frac{1}{2}$ .



20. A sequence of dot-patterns is started below:

Pattern 1	Pattern 2	Pattern 3	Pattern 4
*****	*****	*****	*****
	**	**	**
		**	**
			**

Copy and complete the formula for the number of dots in the  $n^{\text{th}}$  pattern:

*Number of dots in the  $n^{\text{th}}$  pattern = .....*

21. For the following tables, find a formula connecting  $x$  and  $y$  in the form  $y = \dots$  etc.

a)

$x$	$y$
1	4
2	7
3	10
4	13
5	16

b)

$x$	$y$
1	3
2	8
3	13
4	18
5	23

c)

$x$	$y$
1	5
3	9
5	13
7	17
8	19

d)

$x$	$y$
2	3
4	5
6	7
9	10
12	13

e)

$x$	$y$
5	19
3	11
7	27
4	15
11	43

f)

$x$	$y$
1	1
2	4
3	9
4	16
5	25

22. Given that  $a = 3$ ,  $b = 4$ , and  $c = -3$ , work out the values of the following.

- |               |                  |                      |                       |
|---------------|------------------|----------------------|-----------------------|
| a) $a + 2b$ , | b) $3a + b$ ,    | c) $3(a + 2b)$ ,     | d) $a^2 + b^2$ ,      |
| e) $a^2b$ ,   | f) $ab^2$ ,      | g) $ab + c$ ,        | h) $c^2$ ,            |
| i) $a - c$ ,  | j) $a + c$ ,     | k) $a(a + b) + bc$ , | l) $ac - ca$ ,        |
| m) $2a - c$ , | n) $a(2b - c)$ , | o) $3(a + b)^2$ ,    | p) $(a - b)(a + b)$ . |

23. Solve the following equations.

- |                                   |                                |                             |
|-----------------------------------|--------------------------------|-----------------------------|
| a) $4(x - 2) = 2(x + 3)$ ,        | b) $3(2x + 4) = 4(x + 4)$ ,    | c) $3(2x - 1) = 4(x + 1)$ , |
| d) $4(2x + 1) = 6(x + 3)$ ,       | e) $7(x - 3) = 11 - x$ ,       | f) $2(x - 10) = 5 - 3x$ ,   |
| g) $3(x - 1) = 2(x + 7)$ ,        | h) $x + 2(x + 4) = 17$ ,       | i) $2(5 + x) = x + 20$ ,    |
| j) $3(2x + 4) + 2(3x + 2) = 28$ , | k) $100 - 2(10 + x) = 60$ ,    | l) $10 - 3(3 - x) = 4$ ,    |
| m) $10 - x = 12$ ,                | n) $3x + 2(x + 1) = 3x + 12$ , | o) $10 - 3(3 - x) = 16$ .   |

24. a) Add the fractions  $\frac{2x + 1}{3} + \frac{3x - 2}{5}$ , simplifying your answer as far as possible.

b) Use your answer to a) to solve the equation  $\frac{2x + 1}{3} + \frac{3x - 2}{5} = 5$ .

25. Solve the following equations.

- |   |  |  |
|---|--|--|
| a) $\frac{3x + 5}{5} + \frac{2x - 2}{3} = 13$ , | b) $\frac{3x + 2}{4} - \frac{2x + 3}{5} = 2$ , | c) $\frac{4x + 1}{3} - \frac{3x - 5}{5} = 5$ . |
|---|--|--|

26. Work out the values of the following.

a)  $\frac{13 \cdot 6 - 7 \cdot 7}{2 \cdot 1 + 1 \cdot 6}$ ,    b)  $\frac{5678}{27 \cdot 8 + 56 \cdot 3}$ ,    c)  $\frac{50 \cdot 5^2}{120 \cdot 8 - 56 \cdot 3}$ ,    d)  $\frac{12 \cdot 5^2 + 4 \cdot 8^2}{9 \cdot 8 + 117 \cdot 9}$ .

27. Evaluate the following.

a)  $\frac{2\pi(4 \cdot 21)^3}{3}$ ,    b)  $\frac{3\pi(8 \cdot 5)^3}{5}$ ,    c)  $\frac{\pi^2(12 \cdot 8 + 14 \cdot 22)^3}{50}$ ,    d)  $\frac{3\pi + 20}{5\pi}$ .

28. Solve the following simultaneous equations.

a)  $x + y = 10$ ,    b)  $3x + y = 13$ ,    c)  $4x + 3y = 15$ ,  
 $x - y = 4$      $5x - 2y = 7$      $5x - 4y = 11$

d)  $3x + y = 7$ ,    e)  $4x + 2y = 4$ ,    f)  $5x - 3y = 1$ ,  
 $2x - 3y = 12$      $3x - 4y = -19$      $3x - 5y = 7$

29. **On graph paper**, draw a set of axes with  $x$  from  $-4$  to  $5$  and  $y$  from  $-1$  to  $18$ .

i) Draw the following graphs on the same axes:    a)  $y = x + 3$ ,    b)  $y = 9 - 2x$ .

ii) Indicate, by shading the unwanted region, the set of points satisfying:

$$y \geq 0, \quad y \leq x + 3, \quad y \leq 9 - 2x.$$

iii) Use your graph to write down all **integer** pairs of numbers  $x$  and  $y$  satisfying the inequalities above.

30. Draw a set of axes with  $x$  from  $-3$  to  $6$  and  $y$  from  $0$  to  $12$ .

i) Draw the following graphs on the same axes:    a)  $y = 6 + x$ ,    b)  $x + 2y = 6$ .

ii) Use your graphs to solve the simultaneous equations:     $y = 6 + x$   
 $x + 2y = 6$ .

iii) Solve the simultaneous equations in ii) using algebra.

31. a) Copy and complete the table of values for the function  $y = x^2 - 5x + 2$

$x$	-2	-1	0	1	2	3	4	5
$y$	16							2

b) Plot the graph of  $y = x^2 - 5x + 2$  for values of  $x$  between  $-2$  and  $5$ .

32. a) Copy and complete the table of values for the function  $y = 6 - 2x^2$ .

$x$	-3	-2	-1	0	1	2	3
$y$	-12						-12

b) Plot the graph of  $y = 6 - 2x^2$  for values of  $x$  between  $-3$  and  $3$ .

**SHAPE & SPACE.**

33. Calculate the areas of each of the following shapes.

a)

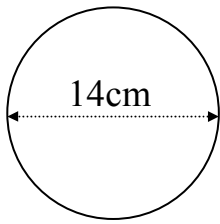

b)

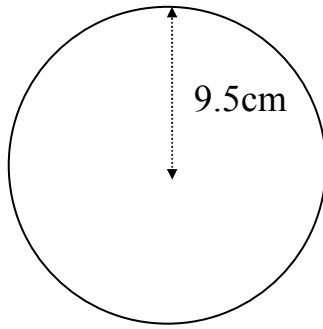

c)

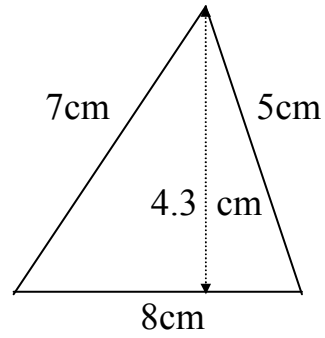

d)

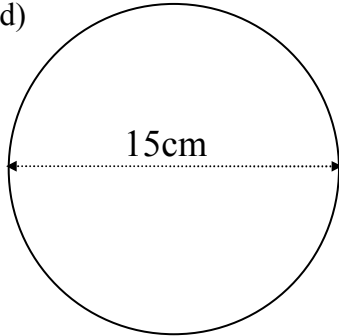

e)

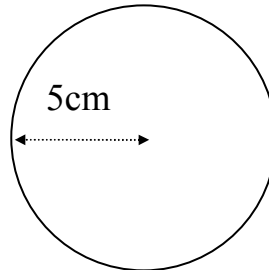

f)

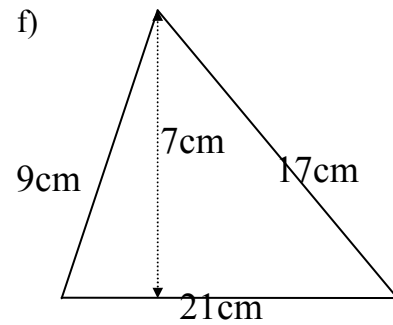

g)

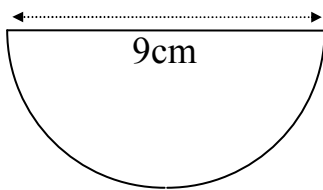

h)

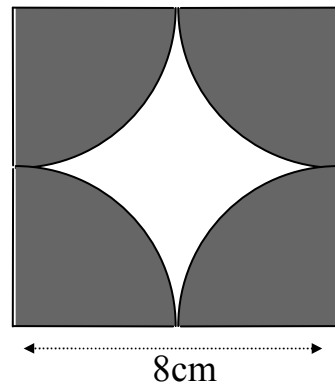

**Shaded region only.**

34. Find the perimeters of the shapes in question 33).

35. A wheel has radius 50 cm

Calculate:

- a) how far the wheel travels when it revolves once,
- b) how far, in metres, the wheel travels when it revolves 60 times,
- c) how many **complete** revolutions the wheel needs to make to travel 80 m.

36. Calculate the areas of the following shapes.

a)

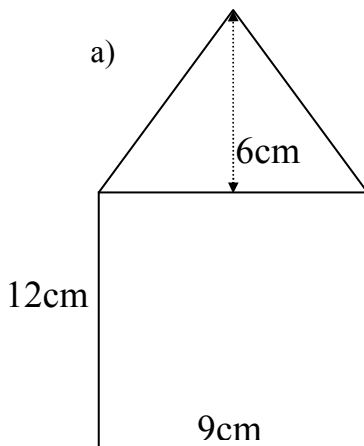

b)

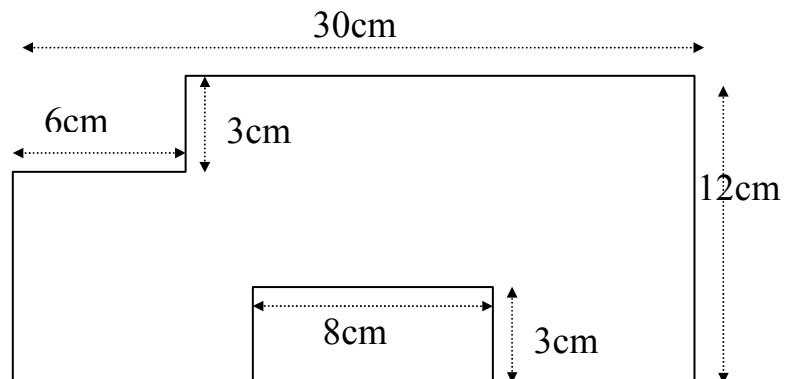

37. Find the volumes of the following solids.

a)

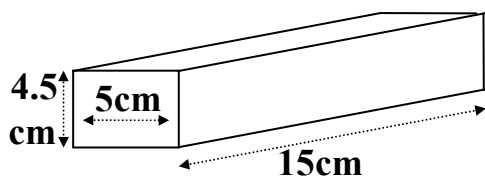

b)

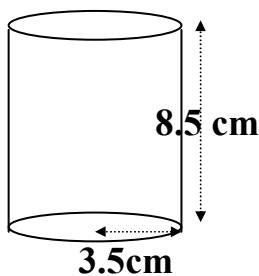

c)

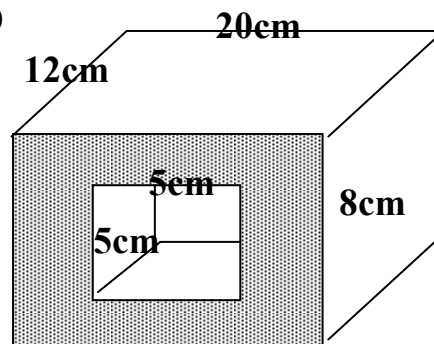

d)

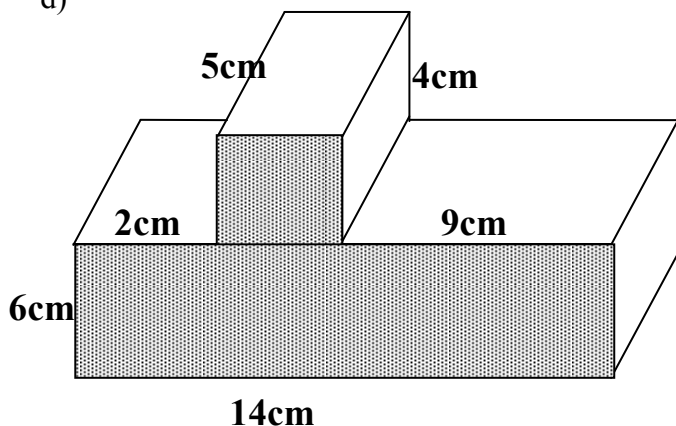

e)

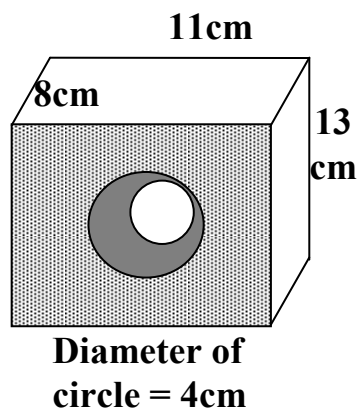

38. On graph paper, using a scale of 1cm to 1 unit on both axes, draw a set of axes with both  $x$  and  $y$  from  $-8$  to  $+8$ .

i) Plot the points  $A(2, 1)$ ,  $B(4, 1)$  and  $C(4, 3)$  and draw the triangle  $ABC$ .

ii) Draw the line  $y = x$  and reflect the triangle  $ABC$  in the line. Label the new triangle 1.

iii) Draw the line  $x + y = 2$  and reflect the triangle  $ABC$  in the line. Label the new triangle 2.

iv) Draw the line  $x = -1$  and reflect the triangle  $ABC$  in the line. Label the new triangle 3.

39. On graph paper, using a scale of 1cm to 1 unit on both axes, draw a set of axes with both  $x$  and  $y$  from  $-8$  to  $+8$ .

i) Plot the points  $A(0, 1)$ ,  $B(2, 1)$ ,  $C(2, 2)$  and  $D(1, 3)$  and join them with straight lines to give a four sided shape  $ABCD$ .

ii) Rotate  $ABCD$  by  $90^\circ$  clockwise about the origin and label the new shape 2.

iii) Rotate shape 2 by  $90^\circ$  clockwise about the origin and label the new shape 3.

iv) Rotate shape 3 by  $90^\circ$  clockwise about the origin.

**[You should end up with the original shape  $ABCD$ !]**

**PROBABILITY.**

40. A black die and a red die are rolled at the same time and the total score is noted

a) Copy and complete the table to show ALL the outcomes.

		BLACK					
		1	2	3	4	5	6
RED	1	2	3	4	5	6	7
	2						
	3						
	4						
	5						
	6						

b) What is the probability of getting a TOTAL of 9 on the two dice ?

c) What is the probability that the number on the black die is LESS than the number on the red die ?

41. Jane and Sarah each select a number between 1 and 5 at random.

a) What is the probability that Jane selects an EVEN number?

b) Draw a table to illustrate ALL of the possible choices and hence work out the probability that Jane and Sarah select the SAME number.

42. A Bag contains 3 banana and 5 lemon sweets.

A boy reaches into the bag and removes two sweets at random.

a) Draw a tree diagram to show the possible outcomes.

b) Calculate the probability that the boy has two banana flavoured sweets.

c) Calculate the probability that the boy has at least one lemon sweet.

43. A Bag contains 7 banana, 6 cherry, 3 lemon and 4 pineapple sweets.

A girl reaches into the bag and removes two sweets at random

Calculate the probability that she has removed

a) two banana flavoured sweets,

b) at least one cherry sweet.

44. A box contains 5 red and 3 blue discs. A second box contains 4 red and 5 blue discs.

A disc is chosen at random from the first box and placed into the second box. A disc is then chosen at random from the second box.

a) Draw a tree diagram to show the possible outcomes.

b) Calculate the probability that the discs chosen from both boxes were red.

c) Calculate the probability that the disc chosen from the **second** box was red.

## ANSWERS.

1. a) 0.35 cm, b) 2000m, c) 200000 cm, d) 1.02 kg,  
e) 3.5 m, f) 4500 g, g) 0.5 km, h) 0.6 kg,  
i) 150 cm, j) 5000 m, k) 7 m, l) 3250 g.
2. a) 6 inches, b) 10 inches, c) 37.5 cm, d) 62.5 cm,  
e) 11 pounds, f) 26.4 pounds, g) 2.27 kg, h) 5.4545... kg,  
i) 16 km, j) 27.2 km, k) 6.25 miles, l) 10.625 miles,  
m) 13.5 litres, n) 6.66... gallons, o) 6.75 litres, p) 32 pints.
3. a) 150 m, b) 25 cm.
4. a) 700 m, b) 20 cm.
5. a) 4.75 km, b) 12 cm.
6. a)  $3.5 \times 10^1$ , b)  $4.21 \times 10^3$ , c)  $1.25002 \times 10^2$ , d)  $9.2 \times 10^0$ ,  
e)  $1.25 \times 10^5$ , f)  $8 \times 10^0$ , g)  $2.5 \times 10^{-2}$ , h)  $1.67 \times 10^{-3}$ ,  
i)  $1 \times 10^1$ , j)  $1 \times 10^0$ , k)  $2.51 \times 10^2$ , l)  $7.2 \times 10^1$ ,  
m)  $1 \times 10^5$ .
7. a)  $3.014 \times 10^7$ , b)  $1.98 \times 10^4$ , c)  $1 \times 10^5$ , d)  $4.21544 \times 10^6$ ,  
e)  $2.0828571 \times 10^4$ , f)  $4.2352941 \times 10^1$ .
8. a)  $\frac{1}{2}$ , b)  $\frac{1}{3}$ , c)  $\frac{1}{4}$ , d)  $\frac{2}{3}$ , e)  $\frac{3}{4}$ , f)  $\frac{3}{5}$ , g)  $\frac{3}{20}$ , h)  $\frac{2}{5}$ , i)  $\frac{5}{6}$ , j)  $\frac{2}{3}$ .
9. a)  $\frac{3}{2}$ , b)  $\frac{7}{3}$ , c)  $\frac{17}{5}$ , d)  $\frac{37}{9}$ , e)  $\frac{43}{4}$ , f)  $\frac{51}{7}$ .
10. a)  $\frac{13}{20}$ , b)  $\frac{3}{8}$ , c)  $\frac{31}{15}$ , d)  $\frac{2}{5}$ , e)  $\frac{8}{33}$ , f) 4.
11. a) £20, b) £12, c) £12, d) £45, e) £2, f) £10, g) £24,  
h) £96, i) £24, j) £28, k) £11, l) £6.60.
12. a) £41.13, b) £139.83, c) £220, d) £620.40.
13. a) 60%, b) 80%, c) 60%.
14. a) 16.66...%, b) 18.52%, c) 25%, d) 24%.
15. a) £10, £25, b) £21.50, £64.50, c) £245, £70, d) £14, £21,  
e) £35, £21, f) £450, £100.
16. £144.
17. £156.
18. a) 31%, 0.31,  $\frac{7}{20}$ , b) 60%, 0.60101,  $\frac{14}{23}$ ,  $\frac{13}{21}$ .
19. a) 18, b)  $4n - 2$ , c) 398.
20.  $2n + 3$ .
21. a)  $y = 3x + 1$ , b)  $y = 5x - 2$ , c)  $y = 2x + 3$ , d)  $y = x + 1$ ,  
e)  $y = 4x - 1$ , f)  $y = x^2$ .
22. a) 11, b) 13, c) 33, d) 25, e) 36, f) 48, g) 9,  
h) 9, i) 6, j) 0, k) 9, l) 0, m) 9, n) 33,  
o) 147, p) -7.
23. a)  $x = 7$ , b)  $x = 2$ , c)  $x = 3.5$ , d)  $x = 7$ , e)  $x = 4$ , f)  $x = 5$ , g)  $x = 17$ ,  
h)  $x = 3$ , i)  $x = 10$ , j)  $x = 1$ , k)  $x = 10$ , l)  $x = 1$ , m)  $x = -2$ , n)  $x = 5$ ,  
o)  $x = 5$ .
24. a)  $\frac{19x - 1}{15}$ , b)  $x = 4$ .
25. a)  $x = 10$ , b)  $x = 6$ , c)  $x = 5$ .
26. a) 1.5945946, b) 67.514863, c) 39.53876, d) 1.403993735.
27. a) 156.28054, b) 1157.5984, c) 3893.9088, d) 1.8732395.
28. a)  $x = 7, y = 3$ , b)  $x = 3, y = 4$ , c)  $x = 3, y = 1$ , d)  $x = 3, y = -2$ ,  
e)  $x = -1, y = 4$ , f)  $x = -1, y = -2$ .
29. iii) (-3, 0)  
(-2, 0), (-2, 1)  
(-1, 0), (-1, 1), (-1, 2)

(0, 0), (0, 1), (0, 2), (0, 3)  
 (1, 0), (1, 1), (1, 2), (1, 3), (1, 4)  
 (2, 0), (2, 1), (2, 2), (2, 3), (2, 4), (2, 5)  
 (3, 0), (3, 1), (3, 2), (3, 3)  
 (4, 0), (4, 1).

30. ii), iii)  $x = -2, y = 4$ .

31. a)

<b>x</b>	-2	-1	0	1	2	3	4	5
<b>y</b>	16	8	2	-2	-4	-4	-2	2

32. a)

<b>x</b>	-3	-2	-1	0	1	2	3
<b>y</b>	-12	-2	4	6	4	-2	-12

33. a)  $153.9 \text{ cm}^2$ ,      b)  $283.5 \text{ cm}^2$ ,      c)  $17.2 \text{ cm}^2$ ,      d)  $176.7 \text{ cm}^2$ ,  
 e)  $78.5 \text{ cm}^2$ ,      f)  $73.5 \text{ cm}^2$ ,      g)  $31.8 \text{ cm}^2$ ,      h)  $50.3 \text{ cm}^2$ .
34. a)  $43.98 \text{ cm}$ ,      b)  $59.7 \text{ cm}$ ,      c)  $20 \text{ cm}$ ,      d)  $47.1 \text{ cm}$ ,  
 e)  $31.4 \text{ cm}$ ,      f)  $47 \text{ cm}$ ,      g)  $23.14 \text{ cm}$ ,      h)  $57.13 \text{ cm}$ .
35. a)  $314.1592654 \text{ cm}$ ,      b)  $188.4955592 \text{ m}$ ,      c) 25 complete revolutions.
36. a)  $135 \text{ cm}^2$ ,      b)  $318 \text{ cm}^2$ .
37. a)  $337.5 \text{ cm}^3$ ,      b)  $327.1 \text{ cm}^3$ ,      c)  $1620 \text{ cm}^3$ ,      d)  $480 \text{ cm}^3$ ,  
 e)  $1043.5 \text{ cm}^3$ .
40. b)  $\frac{1}{9}$ , c)  $\frac{5}{12}$ .
41. a)  $\frac{2}{5}$ , b)  $\frac{1}{5}$ .
42. b)  $\frac{3}{28}$ , c)  $\frac{25}{28}$ .
43. a)  $\frac{21}{190}$ , b)  $\frac{169}{190}$ .
44. b)  $\frac{5}{16}$ , c)  $\frac{37}{80}$ .

## REVISION:- Number

- Change the following as indicated.  
a) 35cm to m,      b) 2km to m,      c) 2km to cm,      d) 1020g to kg,  
e) 350cm to m,      f) 4.5 kg to g,      g) 50 000cm to km,      h) 600g to kg,  
i) 1.5m to cm,      j) 5km to m,      k) 700cm to m,      l) 3.25 kg to g.
- Do the following calculations without a calculator, showing your working IN FULL.  
a)  $478 \times 36$ ,      b)  $14 \overline{)336}$ ,      c)  $16 \overline{)199}$ .
- The scale of a drawing is 1cm to 6m.  
a) How long is a bridge which is 3.5 cm on the drawing?  
b) The length of a path is 45m. What length will the path be on the drawing?
- The scale of a drawing is 1cm to 80m.  
a) How long is a bridge which is 2.4 cm on the drawing?  
b) The length of a path is 450m. What length will the path be on the drawing?
- Do the following calculations, showing ALL your working in full.  
a)  $1.56 + 5.38$       b)  $21.6 - 5.34$       c)  $5.5 - 4.6$       d)  $3.2 \times 2.8$   
e)  $6.24 \times 1.2$       f)  $6.4 \div 8$       g)  $9.35 \div 5$ .
- Write down the answers to the following: (**Do NOT use long multiplication/division!**)  
a)  $105 \times 1000$       b)  $0.124 \times 100$       c)  $30 \div 100$       d)  $1.6 \div 1000$
- Arrange in order of size, putting the smallest first:  
a) 0.24, 0.024, 0.204, 0.04,      b) -3, -7, 1, 0, 2.
- Write the following as powers of 2, eg.  $2048 = 2^{11}$   
a) 4,    b) 32,    c) 128,    d) 2,    e) 4,    f) 16,    g) 8
- Use your calculator to work out the following.  
a)  $(12 + 3) \times 6$ ,      b)  $5.5^2 - 2.5^2$       c)  $\frac{6.21 + 709}{20}$ ,      d)  $\frac{23^2}{8.5 + 12}$ .

# REVISION:- Algebra

1. For each of the following sequences, write down the next 2 numbers:  
 a) 1, 4, 7, 10, .....,      b) 1, 3, 9, 27, .....,      c) 3, 6, 10, 15, .....
2. Solve the following equations:  
 a)  $3x - 1 = 11$ ,      b)  $2x - 5 = x + 6$ ,      c)  $2(x + 3) = x + 1$ ,      d)  $5(x + 1) = 20$ ,  
 e)  $5x + 7 = 52$ ,      f)  $14 - 2x = 24$ ,      g)  $4(x + 1) = 2(x + 6)$ ,      h)  $2(3x - 4) = 4$ ,  
 i)  $2x + 3 = 27$ ,      j)  $4x + 2 = 2x + 12$ ,      k)  $4(x - 2) = x + 4$ .
3. Given that  $a = 2$ ,  $b = 5$ , and  $c = -5$ , work out the values of the following:  
 a)  $a + 2b$ ,      b)  $b + c$ ,      c)  $a - 2c$ ,      d)  $4b^2 + c^2$ ,      e)  $abc$ .
4. Remove the brackets and simplify.    a)  $(x + 1)(x + 3)$ ,    b)  $(x - 2)(x - 1)$ ,    c)  $(2x + 1)(3x + 2)$ .
5. Rearrange the following formulae to make  $x$  the subject.  
 a)  $ax + b = c$ ,      b)  $2(x + a) = b$ ,      c)  $\frac{2x}{a} = b$ ,      d)  $a(2x - a) = a^2$ .
6. A sequence of dot-patterns is started below:

Pattern 1	Pattern 2	Pattern 3	Pattern 4
***	***	***	***
	****	****	****
		****	****
			****

a) Copy and complete the following table for patterns 5 and 6.

Pattern number	Number of dots
1	3
2	7
3	11
4	15
5	.....
6	.....

b) Copy and complete the formula for the number of dots in the  $n^{\text{th}}$  pattern:

*Number of dots in the  $n^{\text{th}}$  pattern = .....*

c) Use your formula to find the number of dots in the 100<sup>th</sup> pattern.

7. A sequence of dot-patterns is started below:

Pattern 1	Pattern 2	Pattern 3	Pattern 4
*	*	*	*
	***	***	***
		***	***
			***

Copy and complete the formula for the number of dots in the  $n^{\text{th}}$  pattern:

*Number of dots in the  $n^{\text{th}}$  pattern = .....*

8. Solve the following equations by trial & improvement.

a)  $x^2 + x = 80$ ,

b)  $x^3 = 37$ .

**Give your answers to 1 decimal place.**

9. Solve the following pairs of simultaneous equations by algebra.

a)  $2x + y = 8$

b)  $3x + y = 11$

c)  $3x - 2y = 8$ .

$3x - y = 7$

$9x + 2y = 28$

$2x + 3y = 1$

**(Use graph paper for these questions.)**

10. On the same set of axes, taking both  $x$  and  $y$  from 0 to 9, draw the graphs of the following lines:

i)  $x + y = 5$ ,

ii)  $x + 3y = 9$ .

Use your graphs to solve the simultaneous equations

$x + y = 5$ .

$x + 3y = 9$

11. On the same set of axes, taking  $x$  from 0 to +10 and  $y$  from  $-4$  to 6, draw the graphs of the following lines:

i)  $x - y = 4$ ,

ii)  $x + 2y = 10$ .

Use your graphs to solve the simultaneous equations

$x - y = 4$ .

$x + 2y = 10$

12. a) Copy and complete the tables of values for the following two functions:

$y = 10 - x$ .

$x$	-1	0	1	2	3
$y$	11				

$y = 10 - 2x$ .

$x$	-1	0	1	2	3
$y$			8		

b) **Using graph paper**, taking values of  $x$  from  $-1$  to  $+3$ , draw the graphs of  $y = 10 - x$  and  $y = 10 - 2x$  on the same set of axes.

13. a) Copy and complete the tables of values for the following two functions:

$y = 5 + x$

$x$	-3	-2	-1	0	1	2	3
$y$	2		4				

$y = \frac{x-2}{2}$ .

$x$	-3	-2	-1	0	1	2	3
$y$	$-2.5$			$-1$			

b) **Using graph paper**, taking values of  $x$  from  $-3$  to  $+3$ , draw the graphs of  $y = 5 + x$  and  $y = \frac{x-2}{2}$  on the same set of axes.

## REVISION:- Probability

1. A black die and a red die are rolled at the same time and the total score is noted

a) Copy and complete the table to show ALL the outcomes.

		BLACK					
		1	2	3	4	5	6
RED	1	2	3	4	5	6	7
	2						
	3						
	4						
	5						
	6						

b) What is the probability of getting a TOTAL of 9 on the two dice ?

c) What is the probability that the number on the black die is LESS than the number on the red die ?

2. Jane and Sarah each select a number between 1 and 5 at random.

a) What is the probability that Jane selects an EVEN number?

b) Draw a table to illustrate ALL of the possible choices and hence work out the probability that Jane and Sarah select the SAME number.

3. Three fair coins are tossed at the same time.

a) List all the ways in which they can land; eg. HEAD, HEAD, HEAD.

b) Find the probability of getting (i) 3 heads, (ii) 2 heads and a tail (in any order)

4. The Queen of Hearts is taken from a pack of cards and not replaced. Find the probability that the next card is:

- a) another Queen,
- b) another Heart,
- c) the Ace of Hearts,
- d) the Six of Diamonds.

5. A four sided die with faces numbered 1 to 4 and a six sided die with faces numbered 1 to 6 are rolled together. The *score* is the sum of the two numbers showing on the dice.

a) Draw a table to show ALL the possible scores.

b) What is the probability that a total of 6 is obtained ?

c) What is the probability that the number on the four sided die is higher than that showing on the six sided die ?

6. It is found that if a drawing pin is thrown, the probability that it lands '*point up*' is  $0.62$ .

What is the probability that a drawing pin **does not** land point up ?

YEAR 9  
HIGHER TIER REVISION

**NUMBER.**

1. **No calculator.** Work out the values of the following.  
a)  $34 \times 56$ ,                      b)  $125 \times 38$ ,                      c)  $8\overline{)424}$ ,                      d)  $12\sqrt{423}$ .
2. **No calculator.** A certain kind of shelf can hold 24 books.  
a) How many books can 25 such shelves hold? **Show your working.**  
b) Mr. Bloggs wishes to store 870 books. How many of these shelves will he need?  
**Show your working.**
3. Write the following numbers in order of size, putting the smallest first:    1, -5, 0, -7.
4. In a certain test, there are 10 questions. Candidates score  
2 for every question answered correctly,  
-1 for every question answered incorrectly, and  
0 for every question they do not answer.  
a) Bob answers 4 questions correctly, 3 questions incorrectly and does not answer the other 2 questions. Calculate his total score.  
b) It is possible to end up with a negative score. Give **two** examples of how a candidate might end up with a score of -2.
5. a) A TV is advertised at £179 + VAT. Taking VAT as 17.5%, calculate the actual selling price of the TV.  
b) A van is advertised at £3500 + VAT. Calculate the actual selling price of the van.  
c) A dress advertised at £150 is to be reduced in a sale by 12%. Calculate the sale price of the dress.
6. a) Mark scores 6 out of 10 in a test. What percentage is this ?  
b) Jane scores 20 out of 25 in a test. What percentage is this ?  
c) Sammy scores 24 out of 40 in a test. What percentage is this ?
7. a) Monthly payments decrease from £300 to £250. Find the percentage decrease.  
b) Monthly payments increase from £540 to £640. Find the percentage increase.  
c) The height of a tree increased from 3 m to 3 m 75 cm in one year. Find the percentage increase.  
d) A company's profits decreased in a year from £250 000 to £190 000. Find the percentage decrease.
8. Mr. and Mrs. Willis have just received their gas bill for the July to September quarter.  
The details of the bill are as follows:
- |                                   |         |
|-----------------------------------|---------|
| Previous meter reading            | 74 203  |
| Present meter reading             | 74 711  |
| Cost per unit is 9 pence          |         |
| Fixed standing charge per quarter | £14.03. |
- Find the total cost of the gas bill.



j)  $3(2x + 4) + 2(3x + 2) = 28,$

k)  $100 - 2(10 + x) = 60,$

l)  $10 - 3(3 - x) = 4,$

m)  $10 - x = 12,$

n)  $3x + 2(x + 1) = 3x + 12,$

o)  $10 - 3(3 - x) = 16.$

18. Solve the equations.

a)  $5x + 3(x - 2) = 100 - 2(x + 3),$

b)  $5x - 3(x - 2) = 30 - 3(x + 3),$

c)  $\frac{4x + 1}{3} = \frac{2x + 4}{2},$

d)  $\frac{3x - 1}{7} + \frac{4x + 1}{3} = 9,$

e)  $\frac{5x + 4}{3} - \frac{3x + 4}{4} = 4,$

f)  $\frac{2x + 5}{5} - \frac{x + 2}{6} = 3.$

19. Solve the following pairs of simultaneous equations.

a) 
$$\begin{aligned} 4x + 3y &= 9 \\ x - 2y &= 5 \end{aligned}$$

b) 
$$\begin{aligned} 6x - 5y &= 22 \\ 2x - 3y &= 10 \end{aligned}$$

c) 
$$\begin{aligned} 3x - 2y &= 19 \\ 2x - 5y &= 31 \end{aligned}$$

d) 
$$\begin{aligned} 3x - y &= 17 \\ 2x + 3y &= 4 \end{aligned}$$

e) 
$$\begin{aligned} x + 5y &= 14 \\ 2x - 3y &= 2 \end{aligned}$$

f) 
$$\begin{aligned} 3x - 2y &= 1 \\ 5x + 3y &= 8 \end{aligned}$$

g) 
$$\begin{aligned} 4x + 3y &= 26 \\ 5x - 2y &= 21 \end{aligned}$$

h) 
$$\begin{aligned} 4x + 3y &= 25 \\ 3x - 2y &= 6 \end{aligned}$$

i) 
$$\begin{aligned} 5x + 3y &= 8 \\ 4x + 2y &= 6. \end{aligned}$$

20. a) Short-sleeved shirts cost  $x$  pounds. What is the cost of 6 of these shirts?  
b) Long-sleeved shirts cost  $y$  pounds. What is the cost of 4 of these shirts?  
c) Write down the total cost of the 10 shirts.  
d) The short-sleeved shirts in (a) are sold for £2 each less than the £ $x$ , if at least 20 are bought. What is the cost of 20 short-sleeved shirts at this new price?

21. a) Marcus worked for a firm that pays him £ $x$  per hour for work done during Monday to Friday. How much was he paid for 30 hours of work during Monday to Friday?  
b) On Saturday and Sunday he gets paid at twice the Monday to Friday rate. How much was he paid for working a total of 8 hours during Saturday and Sunday?  
c) How much was Marcus paid altogether, giving your answer in its simplest form.  
d) Christopher was paid £2 per hour more than Marcus. How much was Christopher paid for 6 hours worked on a Monday?

22. In a certain rectangle the length of each of the longer sides are 5 cm more than the length of each of the shorter sides. Let  $x$  cm denote the length of each of the shorter sides.
- a) Write down, in terms of  $x$ , the length of each of the longer sides.  
b) Write down, in terms of  $x$ , the perimeter of the rectangle. Simplify your answer as far as possible.  
c) The perimeter of the rectangle is 38 cm. Write down an equation in  $x$ . Solve this equation to find the value of  $x$ .

23. In a certain rectangle the length of each of the longer sides are 4 cm more than the length of each of the shorter sides. Let  $x$  cm denote the length of each of the shorter sides.
- Write down, in terms of  $x$ , the length of each of the longer sides.
  - Write down, in terms of  $x$ , the perimeter of the rectangle. Simplify your answer as far as possible.
  - The perimeter of the rectangle is 60 cm. Write down an equation in  $x$ . Solve this equation to find the value of  $x$ .

24. Rearrange the following formulae to make  $x$  the subject.

- |                           |                             |                        |
|---------------------------|-----------------------------|------------------------|
| a) $3x + a = b$ ,         | b) $6(x - a) = 24$ ,        | c) $x(a + 2b) = 10$ ,  |
| d) $\frac{2x}{a} = b$ ,   | e) $a(x + b) = c$ ,         | f) $2x + a = x + 3a$ , |
| g) $5x - 4b = 10b - 2x$ , | h) $6(x + a) = 2(x + 5a)$ . |                        |

25. The volume of the cone shown in the diagram is given by the formula  $V = \frac{\pi r^2 h}{3}$ ,

where  $r$  is the radius of the base circle  
and  $h$  is the height of the cone.

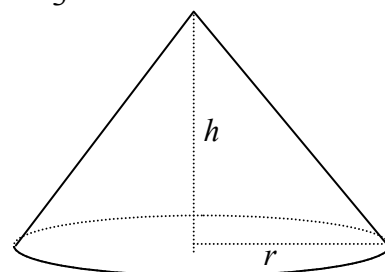

- Find the volume of the cone when the radius is 5 cm and the height is 9 cm.
- Rewrite the formula in the form  $h = \dots\dots\dots$
- Calculate the height of the cone when the volume =  $250 \text{ cm}^3$  and the radius = 8 cm.

26. The surface area of the cylinder shown is given by the formula  $S = 2\pi r^2 + 2\pi rh$ ,

where  $r$  is the radius of the circular base  
and  $h$  is the height of the cylinder.

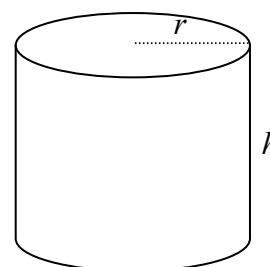

- Find the surface area of the cylinder when the radius is 5 cm and the height is 9 cm.
- Rewrite the formula in the form  $h = \dots\dots\dots$
- Calculate the height of the cylinder when the surface area =  $500 \text{ cm}^2$  and the radius = 6 cm.

27. a) Rearrange the inequality

$$5n - 4 > 3n + 11$$

into the form

$$n > \underline{\text{a number}}.$$

b) Write down the least whole number value of  $n$  which satisfies this inequality.

28. a) Rearrange the inequality

$$4n - 4 < 20 - 2n$$

into the form

$$n < \underline{a \text{ number}}.$$

b) Write down the greatest whole number value of  $n$  which satisfies this inequality.

**SHAPE & SPACE.**

29. Calculate the areas of each of the following shapes.

a)

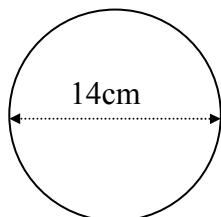

b)

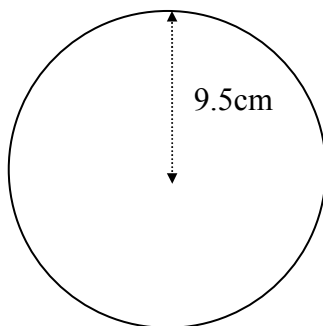

c)

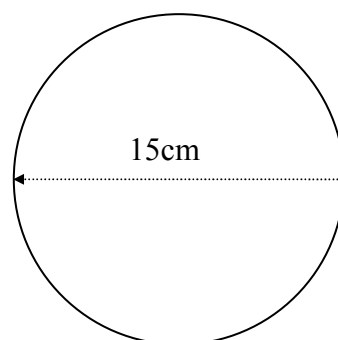

d)

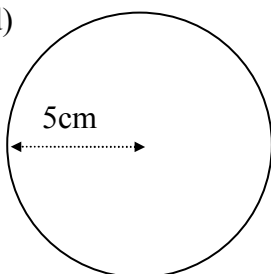

e)

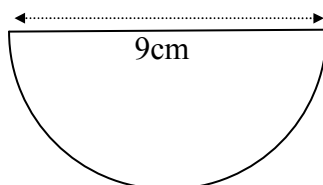

f)

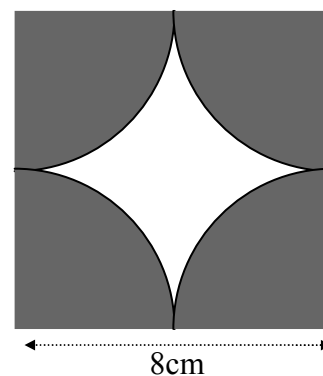

**Shaded region  
only.**

30. Discs of diameter 6 cm are cut from a rectangular plastic sheet of length 60 cm by 42 cm.

a) How many discs can be cut out?

b) Calculate the total area of all the discs that can be cut from the sheet.

c) The plastic left after the discs are cut out is wasted. What percentage of each sheet of plastic is wasted?



31. In the diagram below, angle  $ABC = 90^\circ$ ,  $AB = 9$  cm,  $CD = 28$  cm and  $AD = 41$  cm.

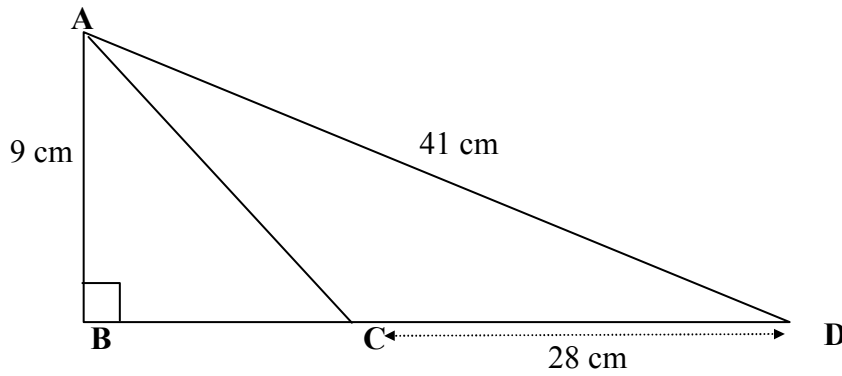

Calculate the following lengths: a)  $BD$ , b)  $BC$ , c)  $AC$ .

32. A ladder which is 7.6 m long is placed against a vertical wall. The foot of the ladder rests on a horizontal floor and is 2.4 m away from the bottom of the wall. Calculate how far the top of the ladder is above the floor.

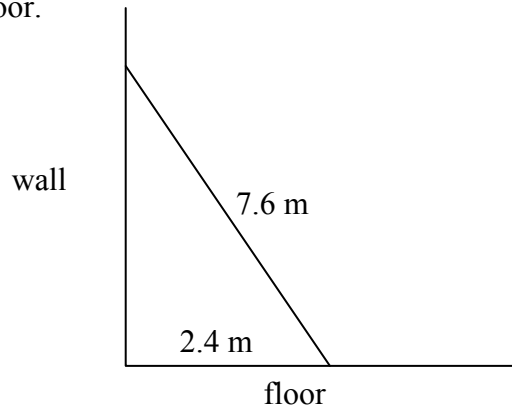

33. The roof of a garage is 4.3 m long and the length of the wall is 3.7 m as shown in the diagram. Use Pythagoras' theorem to calculate the height marked  $h$ .

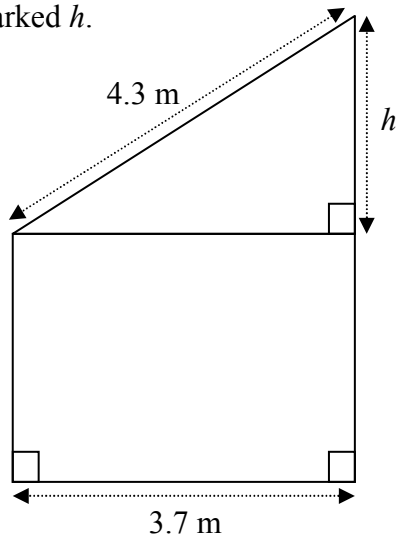

34. The diagram shows a sail  $ABC$  with a support rod  $AD$ . The length of  $AB$  is 10 cm and the distances  $BD$  and  $CD$  are 4 cm and 8 cm respectively. Angle  $ABD$  is  $90^\circ$ .

Calculate the size of angle  $CAD$ .

{Hint:  $S^O_H C^A_H T^O_A$ . Find angle  $CAB$  first.}

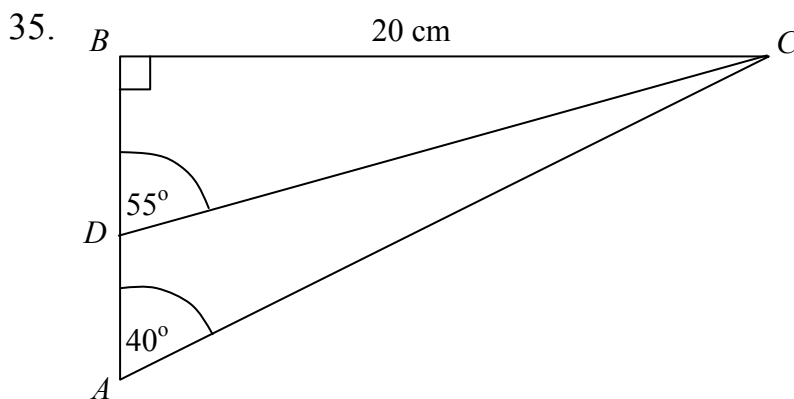
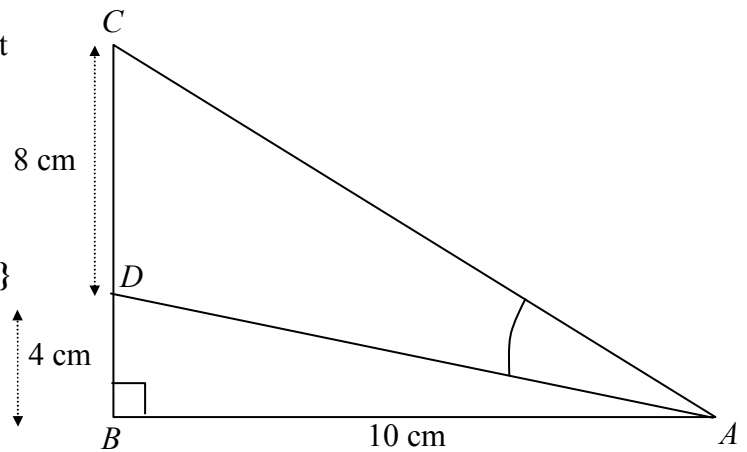

Calculate the length of  $AD$ .

{Hint: calculate  $AB$  and  $BD$  first.}

### DATA HANDLING.

36. The table shows the duration, in completed minutes, of telephone calls made to a certain switchboard in a 1 hour period.

Minutes	Frequency
1 to 5	8
6 to 10	12
11 to 15	3
16 to 20	6
21 to 25	5
26 to 30	1

- a) How many calls were received by the switchboard?  
 b) Calculate an estimate of the MEAN duration of calls received by the switchboard.  
 c) Draw a frequency polygon to represent the data.
37. This table shows a grouped frequency distribution of the marks obtained in a test by the students in a primary school.

Mark	Frequency
0 to 10	9
10 to 20	30
20 to 30	55
30 to 40	30
40 to 50	76

- a) How many pupils sat the test?  
 b) Calculate an estimate of the mean mark.  
 c) Draw a frequency polygon to represent the data.

38. Natalie carries out a survey of the pupils in set 10H to find out how many books each of them has read in the last year. She records her results in this table:

Number of books	1 to 5	6 to 10	11 to 15	16 to 20	21 to 25	26 to 30
Frequency	5	13	5	4	2	1

- a) Calculate an estimate for the mean number of books read per pupil in set 10H.
- b) Simon undertakes the same survey using the same pupils in set 10H. He records his results in this table.

Number of books	1 to 10	11 to 20	21 to 30
Frequency	18	9	3

When he calculates an estimate of the mean number of books read per pupil he gets 10.5

- i) Why is the estimate of the mean Simon calculates different from the estimate of the mean Natalie calculates?
- ii) Why is Natalie's estimate of the mean likely to be better than Simon's?
- c) Natalie also carries out her survey amongst the members of set 10E. The mean number of books read per pupil is 16.

What does this tell you about the reading habits of 10E compared with 10H?

## ANSWERS.

1. a) 1904, b) 4750, c) 53, d) 35.25 or 35 remainder 3.
2. a) 600, b) 37 shelves.
3.  $-7, -5, 0, 1$ .
4. a) 5, b) E.g. 1 correct, 4 incorrect and 5 unanswered, or 2 correct, 6 incorrect and 2 unanswered.
5. a) £210.33, b) £4112.50, c) £132.
6. a) 60%, b) 80%, c) 60%.
7. a) 16.66...%, b) 18.52%, c) 25%, d) 24%.
8. £59.75.
9. a) 31%, 0.31,  $\frac{7}{20}$ , b) 60%, 0.60101,  $\frac{14}{23}$ ,  $\frac{13}{21}$ .
10. £70 : £50.
11. 188 ml.
12. a)  $x = 6.5$ , b)  $x = 6.6$ , c)  $x = 4.0$ .
13. a) 18, b)  $4n - 2$ , c) 398.
14.  $2n + 3$ .
15. a) 17, 20, b) add 3 to the previous number, c)  $n^{\text{th}}$  number =  $3n - 1$ .
16. a) 31, 36, b) add 5 to the previous number, c)  $n^{\text{th}}$  number =  $5n + 1$ .
17. a)  $x = 7$ , b)  $x = 2$ , c)  $x = 3.5$ , d)  $x = 7$ , e)  $x = 4$ , f)  $x = 5$ , g)  $x = 17$ , h)  $x = 3$ , i)  $x = 10$ , j)  $x = 1$ , k)  $x = 10$ , l)  $x = 1$ , m)  $x = -2$ , n)  $x = 5$ , o)  $x = 5$ .
18. a)  $x = 10$ , b)  $x = 3$ , c)  $x = 5$ , d)  $x = 5$ , e)  $x = 4$ , f)  $x = 10$ .
19. a)  $x = 3, y = -1$ .  
b)  $x = 2, y = -2$ .  
c)  $x = 3, y = -5$ .  
d)  $x = 5, y = -2$ .  
e)  $x = 4, y = 2$ .  
f)  $x = 1, y = 1$ .  
g)  $x = 5, y = 2$ .  
h)  $x = 4, y = 3$ .  
i)  $x = 1, y = 1$ .
20. a)  $6x$ , b)  $4y$ , c)  $6x + 4y$ , d)  $20(x - 2)$  or  $20x - 40$ .
21. a)  $30x$ , b)  $16x$ , c)  $46x$ , d)  $6(x + 2)$  or  $6x + 12$ .
22. a)  $x + 5$ , b)  $4x + 10$ , c)  $4x + 10 = 38, x = 7$ .
23. a)  $x + 4$ , b)  $4x + 8$ , c)  $4x + 8 = 60, x = 13$ .
24. a)  $x = \frac{b-a}{3}$ , b)  $x = 4 + a$ , c)  $x = \frac{10}{(a+2b)}$ , d)  $x = \frac{ab}{2}$ , e)  $x = \frac{c}{a} - b$  or  $\frac{c-ab}{a}$ , f)  $x = 2a$ , g)  $x = 2b$ , h)  $x = a$ .
25. a)  $706.8583471 \text{ cm}^3$ , b)  $h = \frac{3V}{\pi r^2}$ , c)  $3.730193979 \text{ cm}$ .
26. a)  $439.8229715 \text{ cm}^2$ , b)  $h = \frac{s - 2\pi r^2}{2\pi r}$ , c)  $7.262911924 \text{ cm}$ .
27. a)  $n > 7.5$ , b) 8.
28. a)  $n < 4$ , b) 3.
29. a)  $153.9 \text{ cm}^2$ , b)  $283.5 \text{ cm}^2$ , c)  $176.7 \text{ cm}^2$ , d)  $78.5 \text{ cm}^2$ , e)  $31.8 \text{ cm}^2$ , f)  $50.3 \text{ cm}^2$ .
30. a) 70, b)  $1979.203372 \text{ cm}^2$ , c) 21.46%.
31. a) 40 cm, b) 12 cm, c) 15 cm.
32. 7.21 m.
33. 2.19 m.
34.  $28.4^\circ$ .
35. 9.83 cm.
36. a) 35, b) 11.71428571.
37. a) 200, b) 31.7.
38. a) 11, b) i) Because he has arranged the data in different groups, ii) Natalie uses more groups, c) 10E read more books on average.