

GCSE MATHEMATICS Higher Tier, topic sheet.

VOLUMES

$Volume\ of\ cylinder = \pi r^2 \times h$ $Volume\ of\ cone = \frac{1}{3} \pi r^2 \times h$
 $Volume\ of\ sphere = \frac{4}{3} \pi r^3$

1. A water tank in the shape of a cuboid has dimensions 3 metres by 2 metres by 2.5 metres as shown.

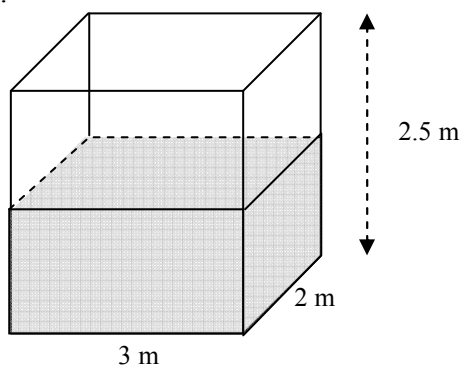

- (a) Into this tank is dropped a solid sphere of radius 30 cm and which is completely submerged by the water. By how much does the level of the water rise? Give your answer to the nearest millimetre.
- (b) Another, identical water tank, has 4 identical solid spheres dropped into the tank which are subsequently submerged by the water. Find the radius of each sphere if the water level rises by 5.5 cm. Give your answer to the nearest centimetre.
2. A container consists of a cylinder on top of a cone. The container is full of oil.

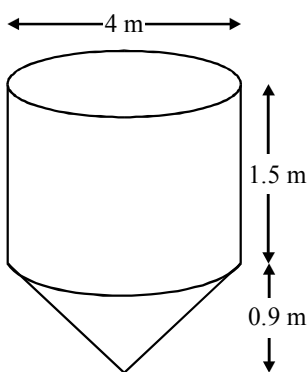

The diameter of both the cylinder and the cone is 4 m.
 The height of the cone is 0.9 m and the height of the cylinder is 1.5 m.
 Calculate the volume of oil in the container. Give your answer in terms of π .

3. The diagram shows a cone.

The cone has a height of 12 cm and a base radius of 3 cm.

- (a) Calculate the volume of the cone.

A sphere has the same volume as the cone.

- (b) Calculate the radius of the sphere.

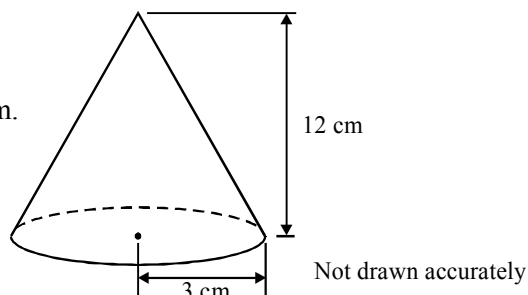

4. A dumbbell is made from 3 cylinders of the same metal with dimensions as shown.

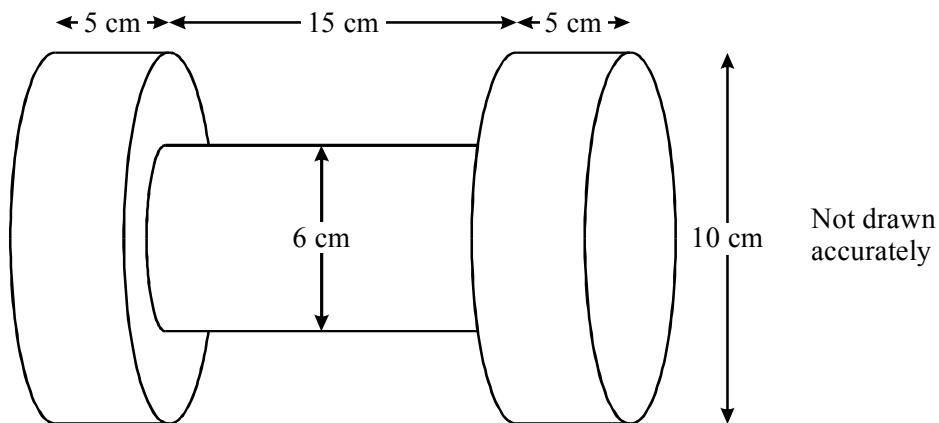

The mass of the dumbbell is 6 kilograms. What is the density of the metal?
(Hint, work out the volume first!)

5. Container *A* consists of a cylinder with a hemisphere on top.

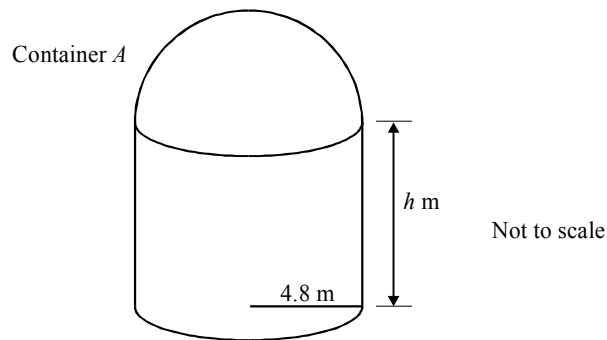

The total volume of container *A* is 337.5 m^3 . The radius of the cylinder is 4.8 m.
 Calculate the height, h , of the cylinder.

6. A thin-walled glass paperweight consists of a hollow cylinder with a hollow cone on top as shown. The paperweight contains just enough sand to fill the cylinder.

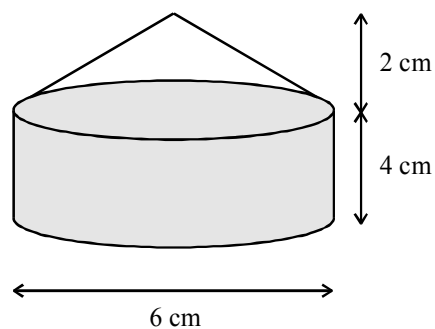

The paperweight is now turned upside down.

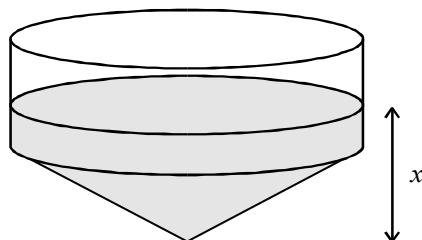

Calculate the depth of the sand, (marked x in the diagram).

SOLUTIONS / ANSWERS.

1. **You are better off working this question in centimetres.**

(a) Volume of sphere = $\frac{4}{3} \pi \times 30^3 = 113097.3355 \text{ cm}^3$.

Thus we are essentially looking for the height, h , of a cuboid with base 300 cm by 200 cm having a volume of 113097.3355 cm^3 .

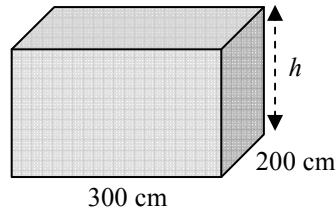

We have $300 \times 200 \times h = 113097.3355$
 which means $h = \frac{113097.3355}{(300 \times 200)}$
 $= 1.8894955592 \text{ cm}$
 $= 1.9 \text{ cm to the nearest mm.}$

(b)

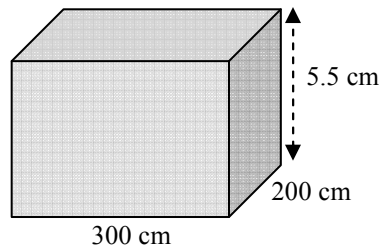

Volume of 4 spheres = $300 \times 200 \times 5.5$
 $= 330000 \text{ cm}^3$.

This means that the volume of a single sphere
 $= 330000 \div 4 = 82500 \text{ cm}^3$.

Thus we must have $\frac{4}{3} \pi \times r^3 = 82500$

$\Rightarrow \pi r^3 = \frac{3 \times 82500}{4} = 61875$.

and thus $r^3 = 61875 \div \pi = 19695.42421$.

Hence $r = \sqrt[3]{19695.42421} = 27 \text{ cm to the nearest cm.}$

2. **The instruction requiring us to leave our answer in terms of π means that we are not to use a calculator.**

Cylinder = $\pi r^2 \times h = \pi \times 2^2 \times 1.5 = 6\pi \text{ m}^3$.

Cone = $\frac{1}{3} \pi r^2 \times h = \frac{1}{3} \times \pi \times 2^2 \times 0.9 = 1.2\pi \text{ m}^3$.

Answer = $6\pi + 1.2\pi = 7.2\pi$.

3. (a) Volume = $\frac{1}{3} \pi r^2 \times h = \frac{1}{3} \times \pi \times 3^2 \times 12 = 113.0973355 \text{ cm}^3$.

(b) $\frac{4}{3} \pi r^3 = 113.0973355$

$\Rightarrow \pi r^3 = \frac{3 \times 113.0973355}{4} = 84.82300165$

and thus $r = \sqrt[3]{\frac{84.82300165}{\pi}} = 3 \text{ cm.}$

4. Volume. Tall cylinders: $\pi \times 5^2 \times 5 = 392.6990817 \text{ cm}^3$.

Long cylinder: $\pi \times 3^2 \times 15 = 424.1150082 \text{ cm}^3$.

Total volume = $2 \times \text{tall cylinder} + \text{long cylinder} = 1209.513172 \text{ cm}^3$.

Density. 1209.513172 cubes of metal weighs 6 kg = 6000 g.

$\Rightarrow 1 \text{ cube weighs } \frac{6000}{1209.513172} = 4.96 \text{ g.}$

Answer = 4.96 g/cm³. (4.96 grams per cm cube of metal).

5. Volume of hemisphere = $\frac{4}{3} \times \pi \times 4.8^3 \div 2 = 231.6233432 \text{ m}^3$.

Therefore, volume of cylinder = $337.5 - 231.6233432 = 105.8766568 \text{ m}^3$.

This means that $\pi \times 4.8^2 \times h = 105.8766568$

and thus $h = \frac{105.8766568}{\pi \times 4.8^2} = 1.46 \text{ m}$ (2 decimal places).

6. Volume of sand = volume of cylinder = $\pi r^2 = \pi \times 3^2 \times 4 = 113.0973355 \text{ cm}^2$.

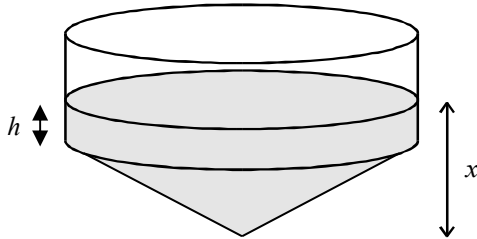

Use h to denote the height of the filled cylinder.

Volume of cone = $\frac{1}{3} \pi r^2 \times h = \frac{1}{3} \times \pi \times 3^2 \times 2 = 18.84955592$.

This means that the volume of the cylinder sitting above the cone = $113.0973355 - 18.84955592 = 94.24777961 \text{ cm}^2$.

Thus $\pi \times 3^2 \times h = 94.24777961$

$\Rightarrow h = \frac{94.24777961}{(\pi \times 3^2)} = 3\frac{1}{3} \text{ cm}$.

Putting this all together gives a total height of $2 + 3\frac{1}{3} = 5\frac{1}{3} \text{ cm}$.

Challenge: It is possible to determine the previous answer without any calculation at all!

Compare the formulas for the volumes of a cone and a cylinder and note that a cone has one-third the capacity of a cylinder with the same radius and same height as the cone.

Can you now explain why $h = 3\frac{1}{3}$?